

(Time: 3 hours)

Max Marks: 80

Note: (1) Question No. 1 is Compulsory.

(2) Answer any three questions from Q.2 to Q.6.

(3) Figures to the right indicate full marks.

Q1.

a) Solve  $(y^2 e^{xy^2} + 4x^3)dx + (2xye^{xy^2} - 3y^2)dy = 0$  5

b) Solve  $(D^2 - 4D + 4)y = e^{2x} + \cos 2x$  5

c) Show that  $\int_0^\infty \frac{e^{-x^3}}{\sqrt{x}} dx * \int_0^\infty y^4 e^{-y^6} dy = \frac{\pi}{9}$  5

d) Change the order of the following integration 5

$$I = \int_0^1 \int_{\sqrt{2x-x^2}}^{1+\sqrt{1-x^2}} f(x,y) dy dx$$

Q2.

a) Evaluate  $I = \iiint \frac{dx dy dz}{(x^2 + y^2 + z^2)^{3/2}}$ , over the volume V bounded by the spheres  $x^2 + y^2 + z^2 = a^2$  and  $x^2 + y^2 + z^2 = b^2$ ,  $(b > a)$  6

b) Show that the length of the arc of the parabola  $y^2 = 4ax$  from the vertex to the end of the latus rectum is  $a[\sqrt{2} + \log(1 + \sqrt{2})]$ . 6

c) Solve by using method of variation of parameters 8

$$\frac{d^2y}{dx^2} + y = \sec x \tan x$$

Q3.

a) Show that  $\int_0^\pi \frac{\log(1+a\cos x)}{\cos x} dx = \pi \sin^{-1} a, 0 \leq a \leq 1$ . Hence 6  
 evaluate  $\int_0^\pi \frac{\log(1+\cos x)}{\cos x} dx$

b) Evaluate  $I = \iint y^2 dx dy$  over the area outside  $x^2 + y^2 - ax = 0$  and inside  $x^2 + y^2 - 2ax = 0$ . 6

c) Evaluate  $I = \int_0^1 \int_0^{1-x} \int_0^{1-x-y} x^2 y z dx dy dz$  8

Q4.

a) Solve  $\cosh x \frac{dy}{dx} = 2 \cosh^2 x \sinh x - y \sinh x$  6

b) Solve  $\frac{d^2y}{dx^2} + 3 \frac{dy}{dx} + 2y = e^{e^x}$  6

c) Show that  $\int_0^\infty \frac{dx}{(e^x + e^{-x})^n} = \frac{1}{4} \beta\left(\frac{n}{2}, \frac{n}{2}\right)$ , hence find the value of  $\int_0^\infty \operatorname{sech}^6 x dx$  8

Q5.

a) Evaluate  $I = \int_{-1}^1 \int_0^{1-x} x^{1/3} y^{-1/2} ((1-x-y)^{1/2}) dx dy$  6

b) Find the area inside the circle  $r = a$  and outside the cardioid  $r = a(1 + \cos\theta)$  6

c) Solve  $xy(1 + xy^2) \frac{dy}{dx} = 1$  8

Q6.

a) Solve  $(D^2 + 2)y = x^2 e^{3x} + x \sin 3x$  6

b) Solve  $x e^x (dx - dy) + e^x dx + y e^y dy = 0$  6

c) Change the order of integration and evaluate 8

$$I = \int_0^a \int_0^x \frac{dx dy}{(y+a)\sqrt{(a-x)(x-y)}}$$

\*\*\*\*\*

Time: 2 Hours

Maximum Marks: 60

- i Question number 1 is compulsory
- ii Attempt any three questions from Q2 to Q6
- iii Assume suitable data wherever required
- iv Figures to the right indicate full marks for that question

QN	Question	Marks
<b>Q1</b>	<b>Attempt any five out of six (3 marks each)</b>	<b>15</b>
<b>A</b>	How the condition, for absent spectra in a grating, is obtained?	
<b>B</b>	Draw and explain energy level diagram for He:Ne laser. What is the role of helium atoms?	
<b>C</b>	With the help of a diagram define the term acceptance angle.	
<b>D</b>	If $\phi(x,y,z) = 3x^2y - y^3z^2$ , Find $\vec{\nabla}\phi$ at the point (-1, -2, 1).	
<b>E</b>	Calculate the velocity of a particle having kinetic energy 3 times its rest mass energy.	
<b>F</b>	Explain, with an example, the significance of surface area to volume ratio in nanotechnology.	
<b>Q2</b>	<b>Attempt all questions</b>	<b>15</b>
<b>A</b>	Discuss with appropriate diagram the phenomenon of Fraunhofer diffraction at a single slit and write the conditions for its maxima and minima.	<b>8</b>
<b>B</b>	With neat and labelled diagrams explain the construction and working of a semiconductor laser. Give its application.	<b>7</b>
<b>Q3</b>	<b>Attempt all questions</b>	<b>15</b>
<b>A</b>	Discuss the phenomenon of Fraunhofer's diffraction at a single slit and obtain the condition for the first minimum.	<b>8</b>
<b>B</b>	What are scalar and vector fields? How is a del operator expressed? Explain the term 'curl of a vector and state its significance'. Show that the divergence of the curl of a vector is zero.	<b>7</b>

- Q4**                      **Attempt all three questions (5 marks each)**                      **15**
- A**    What do you understand by resolving power? How can the resolving power of a grating be increased? Find maximum resolving power of a grating of width 7 cm, illuminated by a laser beam of wavelength  $4800 \text{ \AA}$  having 000 lines per cm.
- B**    State and derive maxwell's equation which describes how the electric field circulates around the time varying magnetic field (Differential form).
- C**    A step index fiber has a core diameter of  $33 \times 10^{-6} \text{ m}$ . the refractive indices of core and cladding are 1.56 And 1.5189 respectively. If the light of wavelength  $1.3 \text{ \mu m}$  is transmitted through the fiber, Determine normalized frequency of the fiber. Weather fiber supports single mode or multimode.
- 
- Q5**                      **Attempt all three questions (5 marks each)**                      **15**
- A**    Explain Gauss's laws for static electric and static magnetic fields in differential and integral forms.
- B**    Explain the concept of relativity. Comment on Galilean and lorentz Transformations
- C**    What is nano material? Explain any one method of production of nano material.
- 
- Q6**                      **Attempt all three questions (5 marks each)**                      **15**
- A**    State and explain application of optical fibre with suitable example
- B**    Explain construction and working of Atomic force Microscope
- C**    What is Time dilation and space contraction using Lorentz transformations obtain expression for them.

\*\*\*\*\*

Time: 2 hours

Max. Marks 60

1. Question No.1 is compulsory
2. Attempt any Three Questions from the remaining Five Questions
3. Figures to the right indicate full marks  
Atomic weight: H = 1, C = 12, N = 14, O = 16, S=32

Q1. Attempt any Five of the following: (15)

- a. Give the principle of cathodic protection? What are the two types of cathodic protection?
- b. Define Spectroscopy and Electromagnetic spectrum.
- c. A cell is constructed from Ni / Ni<sup>2+</sup> and Cu<sup>2+</sup>/Cu half cells. Given E<sup>0</sup>Ni = - 0.257 V and E<sup>0</sup>Cu = 0.337 V. Find out the standard potential of the cell.
- d. How does position of metal in galvanic series affect corrosion.
- e. Explain 'Prevention of waste' principle in green chemistry.
- f. What are fuels? Give the characteristics of good fuel.
- g. A sample of coal has the following composition by mass:  
C = 85%, H = 6%, O = 8%, S = 0.5% and Ash = 0.5%. Calculate HCV using Dulong's Formula.

Q2. a. What is Electrochemical corrosion? Explain Hydrogen evolution mechanism with the help of Diagram. (6)

- b. Define Green chemistry. Calculate the % atom economy for the following synthesis process of propene. (5)

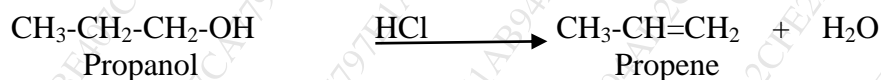

- c. What is knocking. Explain the role of anti-knocking agents. (4)

Q3. a. What is oxidation corrosion. Name the different types of oxide layer formed and state which oxide layers are non-protective in nature. Explain with suitable examples. (6)

- b. 3.2 gm of coal in Kjeldahl's experiment evolved NH<sub>3</sub> gas was absorbed in 40 ml of 0.5 N H<sub>2</sub>SO<sub>4</sub>. After absorption the excess acid required 16 ml of 0.5N NaOH for complete neutralization. 2.5 gm of coal sample in quantitative analysis gave 0.42 gm BaSO<sub>4</sub>. Calculate the % N and S. (5)

- c. What is Electrochemistry? Differentiate between Electrolytic cell and Galvanic cell. (4)

- Q4. a. Calculate the weight of air required for complete combustion of 1Kg coal containing C=65%, H=4%, O=5%, S=2%, N=4%, moisture=10% and remaining ash. (6)
- b. Give conventional and green chemistry route of production of Indigo. Highlight the green chemistry principles in this case. (5)
- c. How is the rate of corrosion influenced by:  
(i) pH of the medium  
(ii) Relative areas of cathode and anode parts. (4)
- Q5. a. Give in tabular form the relation between electromagnetic spectrum, types of spectroscopy and corresponding energy changes. (6)
- b. Explain trans-esterification method for synthesis of bio- diesel. Mention advantages of Bio-diesel. (5)
- c. What are metallic coatings? Distinguish between galvanizing and tinning. (4)
- Q6. a. What are reference electrodes? Give construction and working of any one secondary reference electrode. (6)
- b. What is meant by knocking in internal combustion engine? Define octane number and name any two anti-knock agents. (5)
- c. What are selection rules? Explain any two selection rules. (4)

\*\*\*\*\*

Time: 3 Hrs

Max Marks:60

Note :

- Solve any **FOUR** questions.
- All dimensions are in **mm**.
- Use First Angle Method Of Projection.
- Assume Suitable Dimension If Necessary.

**Q.1** Following figure shows the pictorial view of an object. Draw

- Sectional front view along section A-A
- Top view.
- Right hand Side view
- Insert at least 10 dimensions

[5]  
[4]  
[4]  
[2]

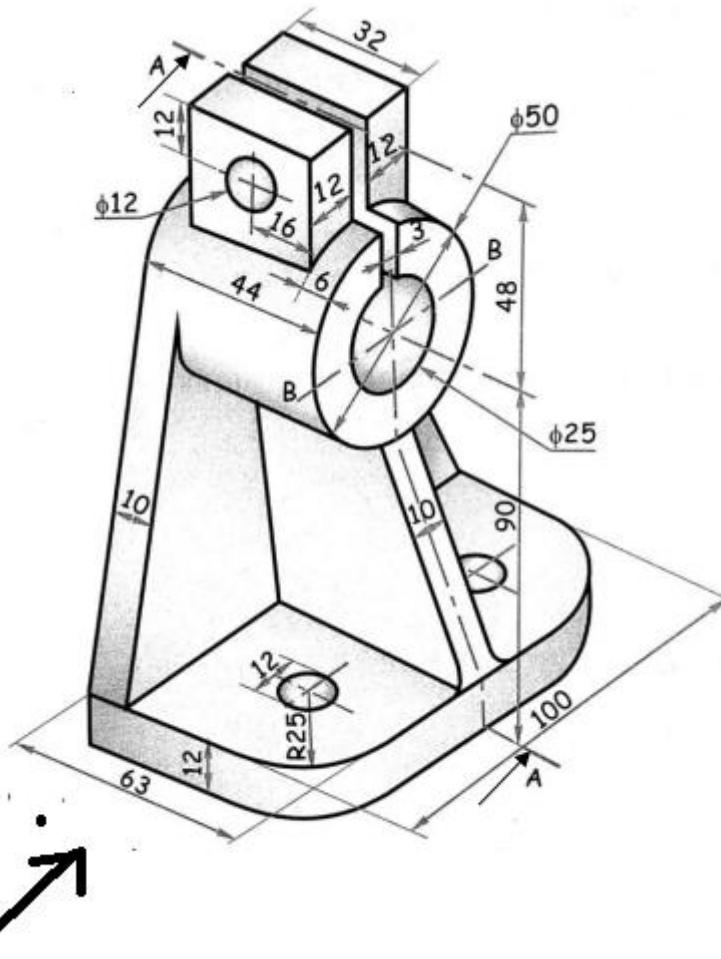

**Q.2** (a) A square Prism side of base 40 mm and axis length 70 mm is kept on the HP on a side of its base such that its axis makes an angle of 45 degrees with the HP. Draw the projections of the prism. [6]

- (b) Draw an isometric view of an object, two views of which are shown in figure: [9]

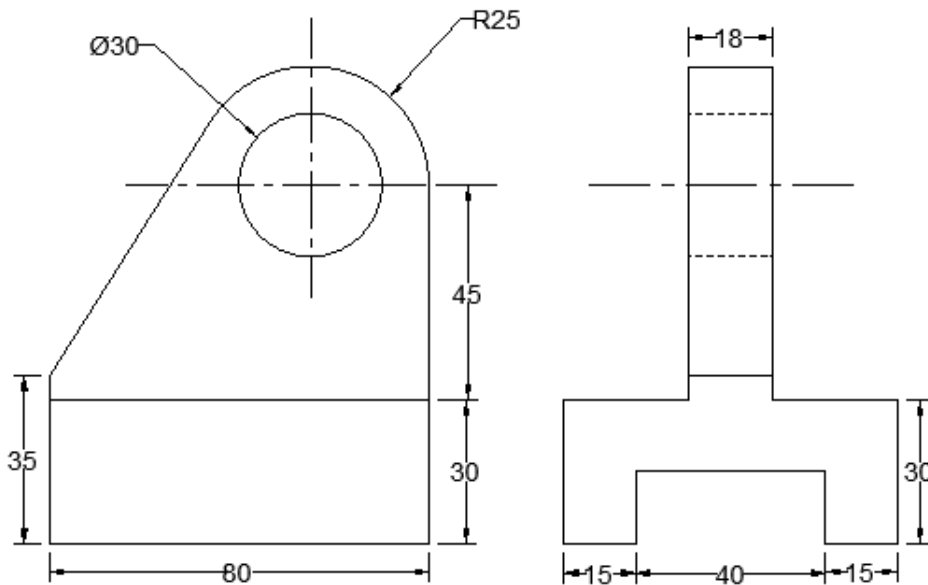

- Q.3** (a) The pictorial view of a machine part is shown in following figure.

Draw

- i) Front view [4]
- ii) Top view [4]
- iii) Insert at least 6 Dimensions. [1]

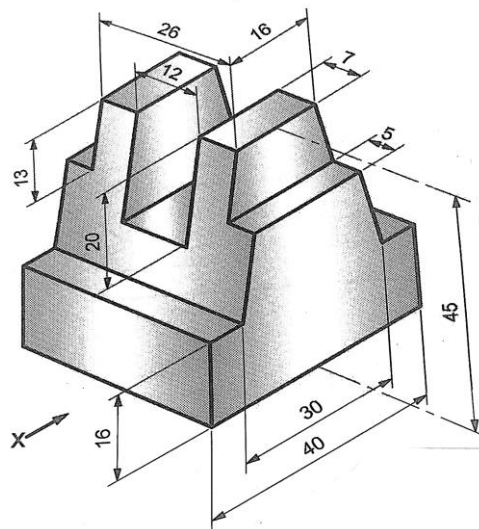

- (b) A circle of 20 mm radius rolls along a straight line without slipping. Draw a curve traced by a point on the circumference for one complete revolution of the circle. Name the curve. [6]

- Q.4** A hexagonal pyramid, side of base 40 mm and axis length 80 mm is resting on HP on an edge of its base such that its apex 60 mm above the HP. Draw its projections when axis of the top view making 45 degrees to VP. [15]



**Q.5**

The top view and front view of a line AB measures 70mm and 60 mm [15]  
 respectively. The line AB is inclined at an angle of 35 degrees to HP. The  
 end A is 15mm above HP and 12mm in front of VP. The other end B is also  
 in the first quadrant. Draw the projections of the line AB. Find its true length  
 and true inclination.

**Q.6 (a)** Figure shows two views of an object. Draw its Isometric view with 'O' as [8]  
 origin.

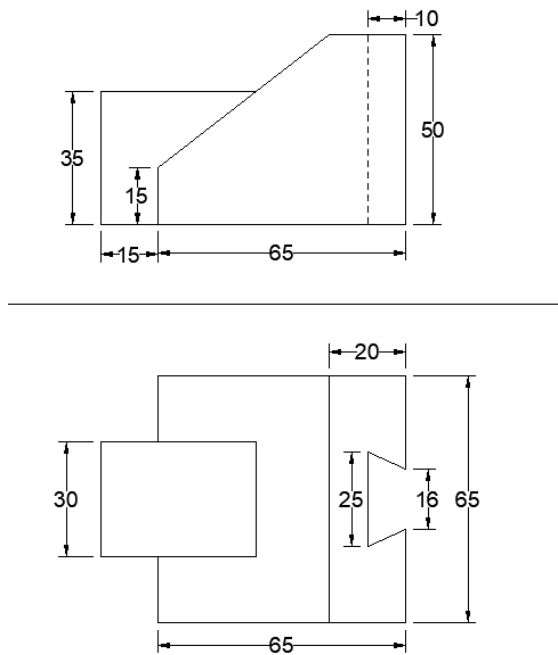

(b) A cone base 60 mm diameter and 75 mm axis length rests on its circular rim [7]  
 on the HP with the axis making an angle of 30 degrees to HP. Draw the  
 projections of the cone.

\*\*\*\*\*

Time: 2 hour

Max. Marks: 60

**NB: 1) Question No.1 is compulsory.****2) Attempt any three questions from question no. 2 to 6.**

- Q1 Solve any three out of the following. 15**
- A** List and explain different components of Computer System. **05**
- B** Write a program to find largest of three numbers using nested if-else. **05**
- C** Explain function prototype with proper example. **05**
- D** Explain the following functions with proper example. **05**
- a) strlen() b) strcmp() c) strcat()
- E** Define Structure and explain the syntax of declaration of Structure with example. **05**
- Q2 15**
- A** Define Flowchart and Draw flowchart to find sum of digits of an accepted number. **05**
- B** Write a program to sort the elements of one dimensional array in ascending order. **05**
- C** Explain conditional operator with proper example. **05**
- Q3 15**
- A** Explain control breaking statements available in C language. **05**
- B** Write a program to calculate value of f(x), if x has different ranges of values **05**
- as below
- $f(x) = x^2 + 2$        $0 \leq x \leq 10$
- $= x^2 + 2x$        $10 < x \leq 20$
- $= x^3 + 2x^2$        $20 < x \leq 30$
- $= 0$        $x > 30$
- C** Write a program to check whether the entered string is palindrome or not. **05**

- Q4** **15**
- A** Explain different data type modifiers available in C language. **05**
- B** Write a program to find square root of a accepted perfect square integer number **without** using standard sqrt( ) function. **05**
- C** Explain the multi-way branching statement available in C language with example. **05**
- Q5** **15**
- A** Write a program using function to check if the entered number is prime number or not. **05**
- B** Define recursion and Write a program to calculate power of a given number using recursive function. **05**
- C** Write a program to accept number of rows from user and display following patterns for expected number of rows. **05**
- 1234  
123  
12  
1
- Q6** **15**
- A** Write a program to find transpose of a square matrix using only one matrix. **05**
- B** Write a program to design a structure Employee with members Employee No, Employee Name, Experience and salary. Read the information of 100 employees and display employee information that is having 5 years or more experience and salary less than Rs. 10,000. **10**

Time: 1:30 hours

Marks : 40

**NB: Q1. is compulsory.**

**Attempt any Three out of the remaining Five questions**

**Figures to the right indicate full marks**

**Answers to the sub questions should be grouped together**

**Q1 Answer the following questions: (10)**

- A. What is Communication? Discuss the cycle of communication with the help of a diagram and suitable example. (05)
- B. i. Communication is the foundation of a successful business relationship. However, our non-verbal actions speak louder than words. Explain this statement with suitable examples. (04)
- ii. Identify the sender, receiver, message, channel and feedback in the following situations: (01)
- The Vice President of an organization instructs the assistant engineer via e-mail to submit his project report within a week. The assistant engineer fails to submit the report.

**Q2. Answer the following questions: (10)**

- A. Write a letter to the Infotech Engineering, Andheri, Mumbai requesting for Internship to improve your practical skills after your semester exams ends i.e from June to August. (Use complete block format ) (05)
- B. i. **Choose the proper subject verb agreement in the following sentences:** (02)
- (a) Neither the parents nor their offspring.... (is/are) to be blamed for the lack of communication.
- (b) The number of institutes offering engineering course in the country....(has/have) almost suddenly skyrocketed.
- (c) None of your suggestions... (is/are) required here.
- (d) Each and every student .....(was/were) informed about the programme.

**ii. Match the following:** (02)

- |                               |                        |
|-------------------------------|------------------------|
| (a) Flammable material        | Caution                |
| (b) Claim letters             | Technical Descriptions |
| (c) Working of Lathe machine  | Warning                |
| (d) Fragile. Handle with care | Adjustment purpose     |

**iii. Use the following pair of words in different sentence to clarify the meaning:** (01)

Career/ Carrier

**Q3. Answer the following questions: (10)**

- A. Using Complete Block Format write a letter complaining to the customer care of Excel Fitness & wellness Hub expressing your grievances against the expired supplements and Protein powder supplied to you. (05)
- B. Short note on: i. You-Attitude ii. Grapevine Communication (04)
- C. **State whether the following statement is True or False.** (01)  
i) "Thanking you in anticipation" is a good way to end up an enquiry letter:  
ii) One cannot not communicate.

**Q4. Answer the following questions: (10)**

- A. Difference between:** (04)  
i. Caution and Warning  
ii. Technical Writing and Literary writing
- B. Describe Analog Voltmeter with the help of definition, principle, diagram, working and Uses. (06)

**Q5. Answer the following questions: (10)**

- A. Instructions to use washing machine. (05)
- B. Arrange the following as warning, caution, description, instruction, and definition (05)**
- (1) Load the spin dryer only up to the Indicated capacity.
  - (2) A hydrometer is an instrument used for measuring the specific gravity of liquids.
  - (3) Open the lid, pour the contents into a bowl and add preservatives and stabilizers one after the other.
  - (4) To avoid injury, keep your fingers away from the flame.
  - (5) The blades may be hard throughout or They may be of the more flexible type which has a soft back and a hard cutting edge.

**Q6 Answer the following questions:**

- A. Read the following passage carefully and answer the multiple-choice questions for comprehension by choosing the correct option (05)**

Technical vocabulary or Terminology is an intrinsic part of every profession. As a profession evolves, certain terms and words tend to establish themselves as nomenclature for that specific profession. Over time, more and more people practicing the same trade or art, use these terms to communicate effectively. Thus, these technical terms become a part of the profession.

Every profession or trade, every art, and every science has its technical vocabulary, the function of which is partly to designate things or processes which have no names in ordinary English and partly to secure greater exactness in nomenclature. Such special dialects, or jargons, are necessary for technical discussion of any kind. Being universally understood by the devotees of the particular science or art, they have the precision of a mathematical formula. Besides, they save time, for it is much more economical to name a process than to describe it: Thousands of

these technical terms are very popularly included in every large dictionary. Yet as a whole, they are rather on the outskirts of the English language than actually within its borders.

Different occupations however differ widely in the character of their special vocabularies. In trades and handicrafts and other vocations, like farming and fishing, that have occupied great numbers of men from remote times, the technical vocabulary is very old. It consists largely of native words, or of borrowed words that have worked themselves into the very fiber of our language. Hence, though highly technical in many particulars, these vocabularies are more familiar in sound, and more generally understood, than most other technicalities. The special dialects of law, medicine, divinity, and philosophy have also, in their older strata, become pretty familiar to cultivated persons, and have contributed much to the popular vocabulary. Yet every vocation still possesses a large body of technical terms that remain essentially foreign, even to educated speech. And the proportion has been much increased in the last fifty years, particularly in the various departments of natural and political science and in the mechanic arts. Here new items are coined with the greatest freedom and abandoned with indifference when they have served their turn. Most of the new coinages are confined to special discussions and seldom get into general literature of conversation. Yet no profession is nowadays, as all professions once were, a closed guild. The lawyer, the physician, the man of science, and the cleric associate freely, with their fellow creatures, and do not meet them in a merely professional way. Furthermore, what is called 'popular science' makes everybody acquainted with modern views and recent discoveries. Any important experiment, though made in a remote provincial laboratory, is once reported in the newspapers and everybody is soon talking about it- as in the case of the Roentgen rays and wireless telegraphy. Thus, our common speech is always taking up new technical terms and making them a common place.

1. The author implies that
  - a. Technical terms do not influence common speech
  - b. The vocabulary of one occupation is not similar to another.
  - c. Common words cannot describe technical processes
  - d. Technical terms are used so that the common man does not understand the occupation.
2. The passage is primarily concerned with
  - a. A new language
  - b. Technical terminology
  - c. Various occupations and professions
  - d. Scientific undertakings
3. Technical vocabulary is very old in which of the following fields?
  - a. Law
  - b. Fishing
  - c. Physics
  - d. Medicine

4. The author's main purpose in the passage is to

- a. Describe a phenomenon
- b. Argue a belief
- c. Propose a solution
- d. Stimulate action

5. Special words used in the technical discussion

- a. Never last long
- b. Should be confined to scientific fields
- c. Should resemble mathematical formulae
- d. May become part of common speech

6. The writer of this article is

- a. In favor of technical vocabulary
- b. Against technical vocabulary
- c. Unconcerned about the changes in common speech
- d. Skeptical about technical vocabulary

7. One word substitution:

(01)

special words and phrases that are used by particular groups of people

8. Suggest a suitable title for the passage

(01)

B. i Define (1) Stapler (2) Engineering Drawing

(02)

ii What does the following non-verbal cues communicate:

(01)

- (1) Slumped posture
- (2) Lean Backwards

iii Elucidate four reasons as to why feedback is important for successful communication.

(02)

\*\*\*\*\*