

Time: 3 Hours

Total Marks: 80

- N.B:** 1) Question No. 1 is compulsory.
 2) Attempt any *THREE* questions out of remaining *FIVE* questions.
 3) Assume suitable data wherever necessary.
 4) Use of Graph paper is allowed.
 5) Figures to the right indicate full marks.

1. Answer of the following questions(*any Four*). 20

- i) Define wavelength standard and state the significance of using it.
- ii) Explain different types of fits with suitable examples and sketches
- iii) Differentiate between roughness and waviness.
- iv) Define and explain i) Resolution; ii) Threshold; iii) Hysteresis
- v) Briefly explain the construction and working of a strain gauge load cell.
- vi) Using Routh's criterion examine the stability of a control system whose characteristic equation is $S^5 + S^4 + 2S^3 + 2S^2 + 3S + 15 = 0$

2. (A) Define Interferometry. Explain Laser Interferometer with neat sketch. 10

(B) Reduce the given block diagram to a it's canonical form and hence obtain equivalent transfer function, $\frac{C(s)}{R(s)}$. 10

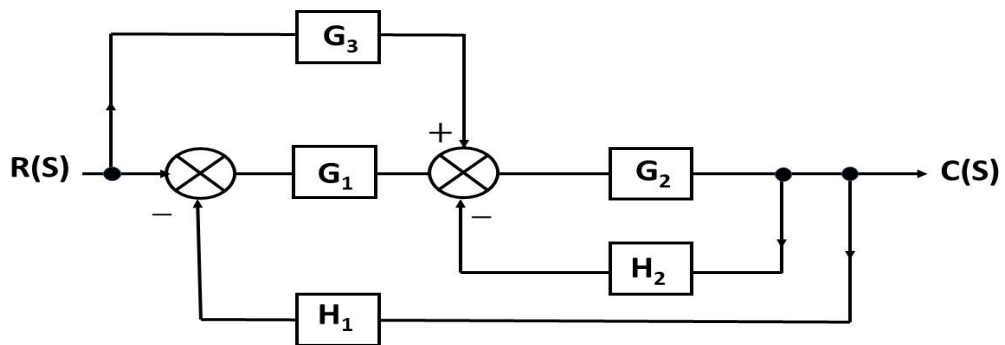

3. (A) Explain generalized measurement system elements with block diagram. Describe functions with suitable examples. 10

(B) A unity feedback system has $G(s) = \frac{K}{s(2+s)(4+s)}$ 10

- a. If $r(t) = 2t$ and $K = 4$, find steady state error.
- b. If it is desired to have steady state error to be 0.4, find corresponding value of "K"
- c. Find steady state error if input is changed to $2+6t$, and value of K to 10.

4. (A) Explain principle, construction and working of *Parkinson Gear Tester* 10
 (B) Draw the root locus and comment on the stability of the control system having open loop transfer function as follows: 10

$$G(s)H(s) = \frac{K}{s^2(s + 1)}$$

5. (A) What are encoders? With a neat sketch, explain the working of an incremental and absolute optical encoder. Give examples of their use. 10
 (B) Design a general type of Go and No Go plug gauge for inspecting a hole 25 d8. Given that: 10

$$i = 0.40 D^{1/3} + 0.001D \text{ micron}$$

$$\text{Tolerance for hole} = 25 i$$

$$\text{Fundamental deviation of the hole} = 16 D^{0.44}$$

Wear allowance 10% of gauge design

6. Write short note on (*any Four*) 20
- i) Floating Carriage Micrometer
 - ii) Repeatability and Reproducibility
 - iii) Ultrasonic Flow Meter
 - iv) Capacitive Pressure Transducer
 - v) Types of Measurement System Inputs
 - vi) Frequency Domain specifications

(3 Hours)

[Total Mark: 80]

- N.B. (1) Question No. 1 is compulsory
 (2) Attempt any **Three** Question from Q. No. 2 to Q. No.6
 (3) Make suitable assumption if required
 (4) Illustrate answers with sketches wherever required

- Q. 1 Solve any **four** questions from the following (Five marks each) 20
- Derive an expression for one dimensional steady state heat conduction through plane wall.
 - Discuss the concept and application of steady and unsteady state heat transfer along with the practical example of each.
 - Calculate the following for an industrial furnace in the form of a black body and emitting radiation at 2500 °C.
 - Monochromatic emissive power at 1.2 μm
 - Wave length at which the emission is maximum
 - Total emissive power of the furnace if it is assumed as real surface with emissivity equal to 0.8
 - Discuss in detail about the effect of engine variables on detonation in Spark ignition engines.
 - A cylinder rod of 1 cm diameter and 1 m long is initially maintained at 300 °C. It is suddenly dropped in oil at 50 °C having convective heat transfer coefficient at 240 W/m²K. Find the time required to cool the rod up to 120 °C. Properties of rod material is as follows:
 Density = 8000 kg/m³. C=400 J/kg.K. k= 60 W/mK
 - Engine oil at 60°C flows over the upper surface of a 5 m-long flat plate whose temperature is 20°C with a velocity of 2 m/s. Determine the total drag force and the rate of heat transfer per unit width of the entire plate.
 Properties of oil are as follows:
 Density=876 kg/m³, Pr = 2870, Thermal conductivity = 0.144 W/m°C, Kinematic viscosity = 242 x 10⁻⁶ m²/s
- Q. 2 (a) An aluminum rod 2 cm diameter and 10 cm long protrudes from the wall maintained at 300 °C. The rod is exposed to surroundings at 15°C. Heat transfer coefficient between rod surfaces an environment is 20 W/m²K. The thermal conductivity of the material is 200 W/mK. Find 12
- Total heat dissipated by rod
 - Temperature of road at 4 cm from the wall
 - Temperature at the end of rod
 - Fin efficiency
- Assume that the rod end is insulated
- (b) What are the different control methods for engine emissions 08
- Q. 3 (a) The following details were noted in a test on a four-cylinder, four-stroke engine, diameter = 100 mm; stroke = 120 mm; speed of the engine = 1600 rpm; fuel consumption = 0.2 kg/min; calorific value of fuel is 44000 kJ/kg; difference in tension on either side of the brake pulley = 40 kg; brake circumference is 300 cm. If the mechanical efficiency is 80%, calculate 10
- brake thermal efficiency
 - indicated thermal efficiency
 - indicated mean effective pressure
 - brake specific fuel consumption

- (b) Derive an expression for temperature distribution and heat dissipation in a straight fin of rectangular profile for insulated tip. 10
- Q. 4 (a) A furnace walls made up of three layers, one of fire brick, one of insulating brick and one of red brick. The inner and outer surfaces are at 870°C and 40°C respectively. The respective coefficients of thermal conductivities of the layer are 1.0, 0.12 and 0.75 W/mK and thicknesses are 22 cm, 7.5 cm, and 11 cm. Assuming close bonding of the layer at their interfaces, find the rate of heat loss per sq. meter per hour and the interface temperatures if the convective heat transfer coefficient of the atmosphere $40 \text{ W/m}^2\text{ }^{\circ}\text{C}$ and atmospheric temperature is 20°C . 12
- (b) Discuss about the actual and ideal valve timing diagram for four stroke petrol engine. 08
- Q. 5 (a) A four stroke gas engine has a cylinder diameter of 25 cm and stroke 45cm. The effective diameter of the brake is 1.6m. The observations made in the test of the engine were as follows. 12
 Duration of the test 40 minute, total number of revolutions = 8080. Total no of explosions = 3230, net load on the brake = 90 kg, mean effective pressure = 5.8 bar, volume of gas used = 7.5 m^3 , pressure of gas indicated in a meter = 136 mm of water of gauge, atmospheric temperature = 17°C , calorific value of the gas 19 MJ/m^3 at NTP. Rise in temperature of the jacket cooling water = 45°C , Cooling Water Supplied 180 Kg. Draw up the heat balance sheet and estimate the indicated thermal efficiency and brake thermal efficiency. Assume atmospheric pressure as 760 mm of Hg
- (b) State and explain different factors affecting on ignition delay period in compression ignition engine 08
- Q. 6 (a) Water (mass flow rate of 1.4 kg/s , $C_p = 4.187 \text{ kJ/kgK}$) is heated from 40°C to 70°C by an oil (mass flow rate 2 kg/s , $C_p 1.9 \text{ kJ/kgK}$) entering at 110°C in a counter flow heat exchanger. If overall heat transfer coefficient is $350 \text{ W/m}^2\text{K}$, Calculate the surface area required. Also find the surface area required if it's a parallel flow heat exchanger. 08
- (b) Explain the following (**Four marks each**) 12
- i) What is the governing law of diffusion mass transfer?
 - ii) Draw a boiling curve for water and show and explain the different boiling regimes. Explain the phenomenon of condensation.
 - iii) Derive an expression for log mean temperature difference in parallel flow heat exchanger. State your assumption

Time: 3 Hours

Total Marks: 80

Instructions:

- i. Question No.1 is compulsory
- ii. Attempt any 3 out of the remaining questions
- iii. Use your judgement for unspecified data, if any but justify the assumption.
- iv. Numbers to the right indicate marks.

- Q1.** Attempt any four of the following sub questions: (20)
- a. What do you mean by critical speed of a shaft, derive an expression for critical frequency for an undamped shaft. (5)
 - b. A vertical spring mass system has a mass of 0.5 kg and an initial deflection of 0.2 cm. find the spring stiffness and natural frequency of the system. (5)
 - c. Compare viscous and coulomb damping. Mention at least five points of difference. (5)
 - d. Explain the meaning of vibration isolation and transmissibility. List at least four vibration isolation materials. (5)
 - e. Why does gyroscopic couple occurs. Derrive an expression for Gyroscopic couple from first principle. (5)
- Q2.a** A machine part weighing 20 N vibrates in a viscous medium. Determine the damping coefficient when a harmonic exciting force of 25 N results in resonant amplitude of 0.01 m with a period of 0.2 sec. if the same system is excited by a harmonic force of frequency 4 Hz. What will be the percentage increase in the amplitude of forced vibration when the dash pot is removed? (10)
- Q2.b** The turbine rotor of a ship has a mass of 2000 kg and rotates at a speed of 3000 r.p.m. clockwise when looking from a stern. The radius of gyration of the rotor is 0.5 m. Determine the gyroscopic couple and its effects upon the ship when the ship is steering to the right in a curve of 100 m radius at a speed of 16.1 knots (1 knot = 1855 m/hr). Calculate also the torque and its effects when the ship is pitching in simple harmonic motion, the bow falling with its maximum velocity. The period of pitching is 50 seconds and the total angular displacement between the two extreme positions of pitching is 12° . Find the maximum acceleration during pitching motion. (10)
- Q3.a** The crank-pin circle radius of a horizontal engine is 300 mm. The mass of the reciprocating parts is 250 kg. When the crank has travelled 60° from I.D.C., the difference between the driving and the back pressures is 0.35 N/mm². The connecting rod length between centres is 1.2 m and the cylinder bore is 0.5 m. If the engine runs at 250 r.p.m. and if the effect of piston rod diameter is neglected, calculate : 1. pressure on slide bars, 2. thrust in the connecting rod, 3. tangential force on the crank-pin, and 4. turning moment on the crank shaft. (10)
- Q3.b** A gun barrel having mass 560kg is designed for following data : Initial recoil velocity 36m/sec. Recoil distance on firing 1.5m Determine :i) Spring constant ii)Damping coefficient iii.) time required by barrel to return to a position of 0.12m from its initial position. (10)

- Q4.a** A Porter governor has all four arms 250 mm long. The upper arms are attached on the axis of rotation and the lower arms are attached to the sleeve at a distance of 30 mm from the axis. The mass of each ball is 5 kg and the sleeve has a mass of 50 kg. The extreme radii of rotation are 150 mm and 200 mm. Determine the range of speed of the governor. (10)
- Q4.b** Find the natural frequency of the system shown in figure by no slip. (10)

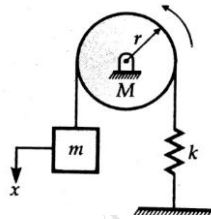

- Q5.a.** A five cylinder in-line engine running at 750 r.p.m. has successive cranks 144° apart, the distance between the cylinder centre lines being 375 mm. The piston stroke is 225 mm and the ratio of the connecting rod to the crank is 4. Examine the engine for balance of primary and secondary forces and couples. Find the maximum values of these and the position of the central crank at which these maximum values occur. The reciprocating mass for each cylinder is 15 kg. (10)
- Q5.b** A vehicle has a mass of 1200 kg. The suspension system has a spring constant of 400 kN/m and damping ratio 0.5. If the vehicle speed is 100 km/hr. determine the displacement amplitude of vehicle. The road surface varies sinusoidal with an amplitude of 0.05 m and wavelength of 6 m. (10)
- Q6.a** A connecting rod of an I.C. engine has a mass of 2 kg and the distance between the centre of gudgeon pin and centre of crank pin is 250 mm. The C.G. falls at a point 100 mm from the gudgeon pin along the line of centres. The radius of gyration about an axis through the C.G. perpendicular to the plane of rotation is 110 mm. Find the equivalent dynamical system if only one of the masses is located at gudgeon pin. (5)
- Q6.b** Explain vibration based condition monitoring and fault diagnosis in rotating machine. (5)
- Q6.c** A vibrometer having a natural frequency of 4 rad/sec and $\xi = 0.2$ is attached to a structure that performs a harmonic motion. If the difference between the maximum and the minimum recorded values is 8 mm, find the amplitude of motion of the vibrating structure with its frequency is 40 rad/s. (10)

(3 Hours)

Total Marks: 80

- N.B.: 1) Question No. 1 is compulsory.
 2) Attempt any three questions out of remaining five questions.
 3) Assume suitable data if required.

Q1 Solve any 4

[Each 5 Marks]

- i) Explain with neat sketch the Finite Element methods.
- ii) What is Boundary Condition? Explain its type in brief ?
- iii) Derive the shape function for One Dimensional Linear Element in Natural Coordinates.
- iv) What are the sources of Errors in FEA?
- v) Explain in brief Jacobian Matrix in FEA.
- vi) Write in brief about Consistent and Lumped mass matrix.

Q2 a) Solve the following differential equation using Galerkin Method. [12]

$$\frac{d^2u}{dx^2} + 5 = 0; \quad \text{For } 0 < x < 1$$

Boundary Conditions are $x = 0$ and $u = 0$ and at $x = 1$; $\frac{du}{dx} + u = 0$

Find $u(0.2) = ?$

- b) What is Convergence in FEA? Explain its types in brief. [04]
- c) Explain the Principle of minimum total potential with suitable example. [04]

Q3 a) Find the temperature at interfaces and heat transfer per unit area through the wall. [10]

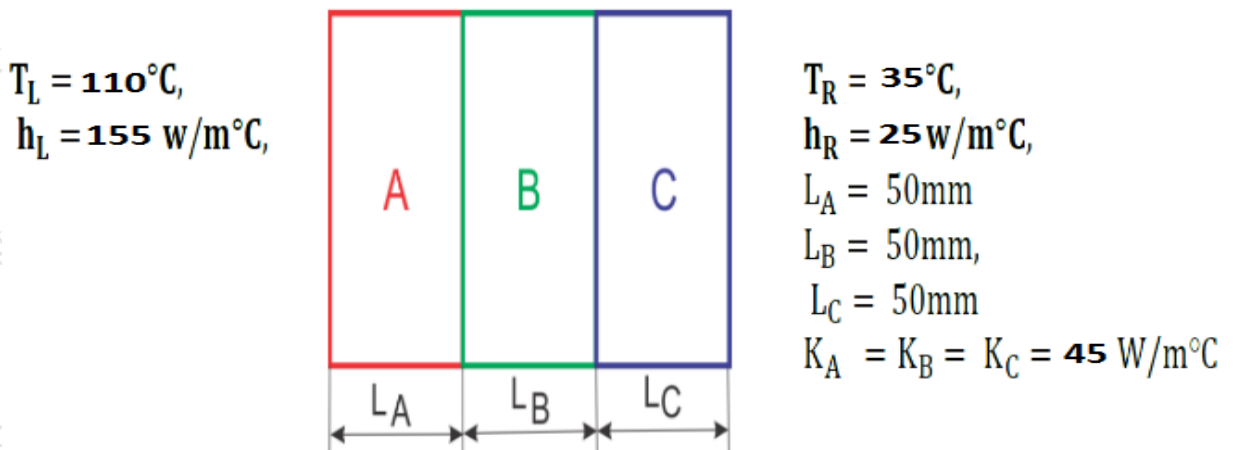

Where K- denotes thermal conductivity, h- denotes heat transfer coefficient and T-temperature. Where f is the weight of the bar. Consider one end of the bar to be fixed and other end free.

b) Develop the finite element equation for the most general element using Rayleigh Ritz Method for vertical bar with axial loading. The governing differential equation is given below [10]

$$\frac{d}{dx} \left(EA \frac{du}{dx} \right) + f = 0 \quad ; 0 \leq x \leq L$$

Q4 a) Analyze the truss for displacement Shown in fig [12]
Take $E = 200 \text{ GPa}$ and $\text{Area} = 100 \text{ mm}^2$

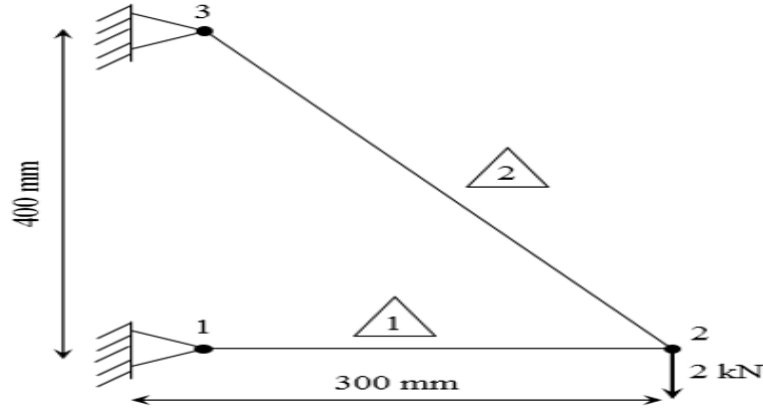

b) For the triangular element shown in figure below fig

$$U_1 = 2, U_2 = 3, U_3 = 5,$$

$$V_1 = 1, V_2 = 2, V_3 = 3$$

Where U, V are displacement in x and y at node 1, 2, 3 respectively. Obtain the displacement of point P .

[08]

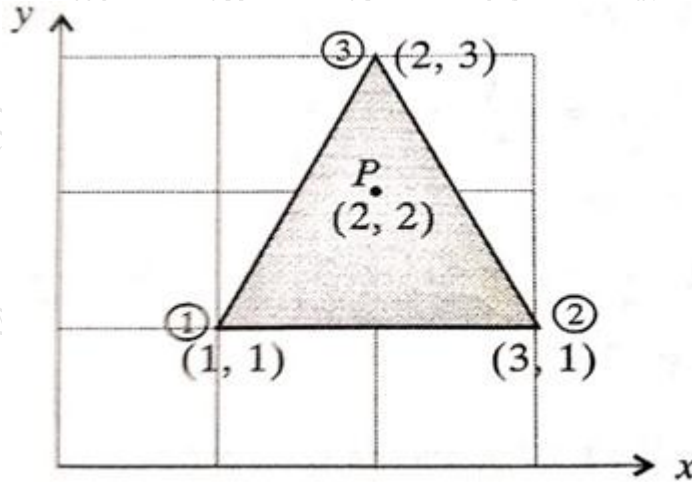

Q5 a) For 2D loaded plat shown in below figure below. Determine the displacements of nodes 1 and 2 and the element stresses using the plane stress conditions. Assume thickness as 12 mm, $E = 235 \text{ GPa}$ and poisons ratio = 0.20, All Dim are in mm [12]

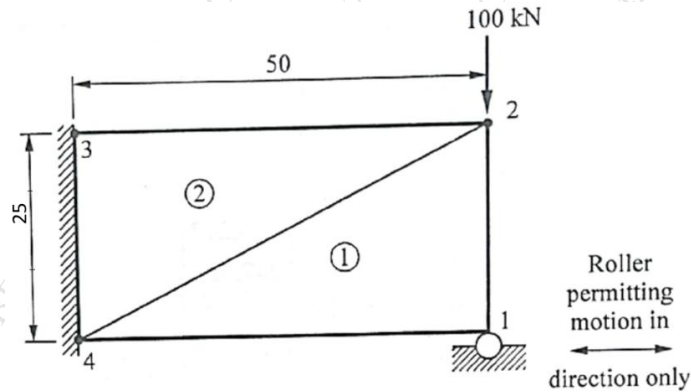

b) A three spring system with stiffness (k) and loads (p) are shown in figure. Calculate the displacement at nodal points. [08]

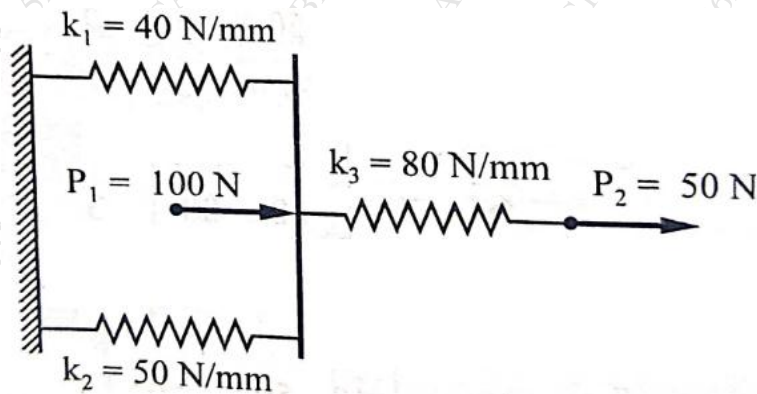

Q6 a) Find natural frequency of axial vibration of a bar of uniform cross section of 20 mm^2 and length 1 m. Take $E = 210 \text{ GPa}$ and density = 8000 kg/m^3 . Assuming mass to be uniformly distributed across the element. [8]

b) A beam having cross sectional of radius 10 mm and length of 100 mm, with young's modulus $2.5 \times 10^5 \text{ N/mm}^2$ and poison's ratio 0.3 is fixed at one end, and a transverse load of 100 N is applied at the other end. Calculate the displacement at various node points. [12]

Time: 3 Hours

Marks: 80

- 1) Question No. 1 is compulsory.
- 2) Answer any three out of the remaining five questions.
- 3) Figures to the right indicate full marks.
- 4) Illustrate answers with neat sketches wherever required.

- Q1 a) How optimisation problems can be classified (4)
- b) Explain dual and primal relationship (4)
- c) Illustrate difference in linear and nonlinear optimization problem with suitable example. (4)
- d) State methods of normalization and explain any one. (4)
- e) Explain Taguchi's loss function (4)

- Q2 a) Solve the following problem by simplex method (10)
- Maximize $Z = 40x_1 + 50x_2$
 Subject to $2x_1 + 3x_2 \leq 3$
 $8x_1 + 4x_2 \leq 5$
 $x_1, x_2 \geq 0$

- b) A shop keeps a stock of products of a particular brand. Previous experience shows the daily demand pattern for the product with associated probabilities, as below. Use the following sequence of random numbers to simulate the demand for the next 10 days. And estimate the average daily demand based on simulated data. (10)

Daily Demand (no.s)	0	10	20	30	40	50
Probability	0.01	0.2	0.15	0.5	0.12	0.02

Use Random Numbers : 25, 39, 65, 76, 12, 05, 73, 89, 19, 49

- Q3 a) Use the method of Lagrangian multipliers to solve the following NLP problem. (10)
 Does the solution maximize or minimize the objective function ? Optimize $Z = 2x_1^2 + x_2^2 + 3x_3^2 + 10x_1 + 8x_2 + 6x_3 - 100$
 subject to the constraint $g(x) = x_1 + x_2 + x_3 = 20$ and $x_1, x_2, x_3 \geq 0$
- b) A company has two plants, each of which produces and supplies two products: A and B. The plants can each work up to 16 hours a day. In plant 1, it takes three hours to prepare and pack 1,000 gallons of A and one hour to prepare and pack one quintal of B. In plant 2, it takes two hours to prepare and pack 1,000 gallons of A and 1.5 hours to prepare and pack a quintal of B. In plant 1, it costs Rs 15,000 to prepare and pack 1,000 gallons of A and Rs 28,000 to prepare and pack a quintal of B, whereas in plant 2 these costs are Rs 18,000 and Rs 26,000, respectively. The company is obliged to produce daily at least (5)

- 10 thousand gallons of A and 8 quintals of B. Formulate this problem as an LP model to find out as to how the company should organize its production so that the required amounts of the two products be obtained at the minimum cost
- c) State various Linear programming methods and state its suitability with illustration (5)
- Q4 a) What are the various non-traditional optimisation techniques? Explain any one with illustration. (10)
- b) Discuss in brief some applications of Optimization in Engineering (5)
- c) A manufacturing firm produces two types of products: A and B. The unit profit from product A is Rs 100 and that of product B is Rs 50. The goal of the firm is to earn a total profit of exactly Rs 700 in the next week. Formulate goal programming model. (5)
- Q5 a) Explain multi attribute decision making with suitable illustration. (10)
- b) Find the maxima and minima of the function (5)
 $f(x) = -x^3 + 3x^2 + 9x + 10$, $-2 < x < 4$
- c) Explain concept of Dynamic programming (5)
- Q6 a) Explain design of experiments. Explain its application and state its importance. (10)
- b) What we mean by full factorial and fractional factorial experiments. (5)
- c) Explain the terms Local optimum, global optimum and saddle point. (5)
