

(3 Hours)

Total Marks: 80

N.B.1. Question No. 1 is Compulsory.

2. Attempt any 3 more questions from remaining five.
3. Assume suitable data if necessary, and mention the same clearly.
4. Figures to the right indicate full mark.
5. Take $g = 9.81 \text{ m/s}^2$

Q1 a) Determine analytically the resultant of the four concurrent forces shown in fig. [4]

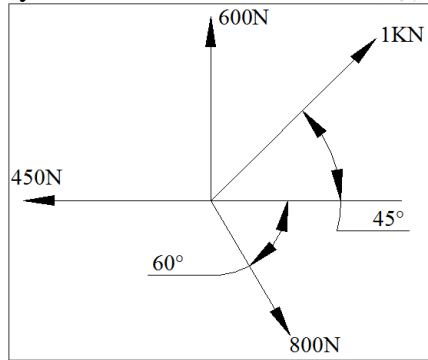

b) A cylinder with 500 N weight is resting in an unsymmetrical groove as shown in figure. Determine the reactions at the points of contacts. [4]

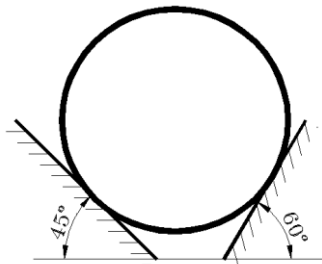

c) Explain Angle of friction and cone of friction. [4]

d) The motion of a particle is defined by the relation $v = 6t^2 - 5t - 2$ where v is in m/s and t is in sec. If the displacement $x = 2\text{m}$ at $t=0$, determine the displacement and acceleration at $t=2$ sec. [4]

e) A car travelling at a speed of 25m/s suddenly applies brakes and comes to stop after skidding 68 m. Determine

- (i) Time need to stop the car
- (ii) Coefficient of friction between the tyre and the road [4]

Q2a) Find the tension in the cable at C and the reaction at the hinge A. Hanging weight is 20N. [8]

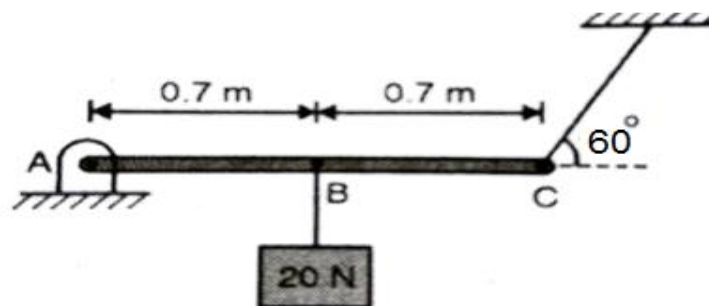

- b) Determine the resultant of a given system of forces shown in figure. Find the point of application of the resultant on the horizontal bar AD (length=8m), with respect to point A. Inclined force 100kN is perpendicular to bar DE(length=4m). [6]

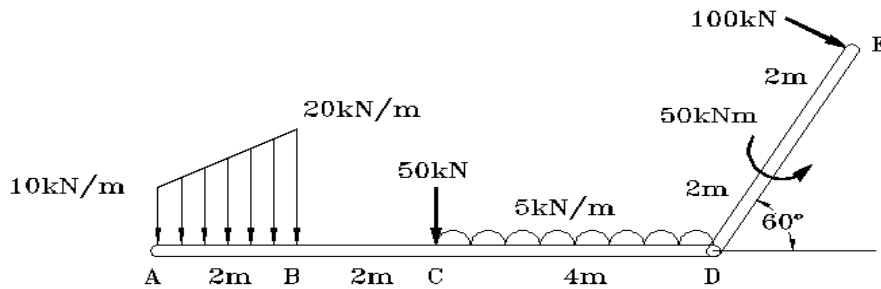

- c) If a ball is thrown vertically down with a velocity of 10m/s from a height of 3m. find the maximum height it can reach after hitting the floor, if the coefficient of restitution is 0.5. [6]

- Q3 a) A circular hole of radius 30mm, with centre 70mm away from **y-axis** is removed from the given thin plate. Determine centroid of the remaining portion of the plate. Plate is symmetrical about **X-axis**. [8]

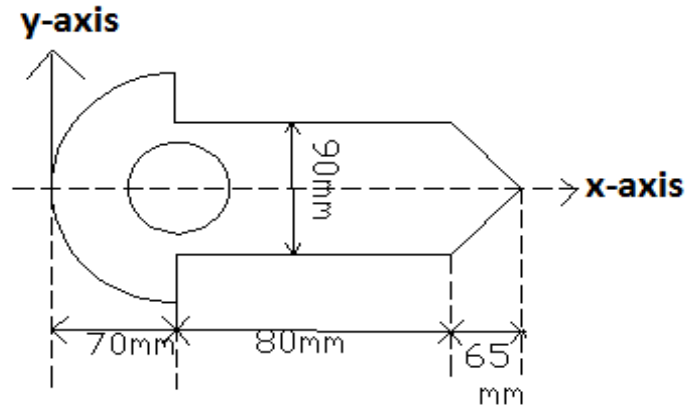

- b) The 10kg mass slides from rest at A along the frictionless rod. Determine the speed at B. Stiffness of the spring $K= 80 \text{ N/m}$. Unstretched length of spring is 0.3m. [6]

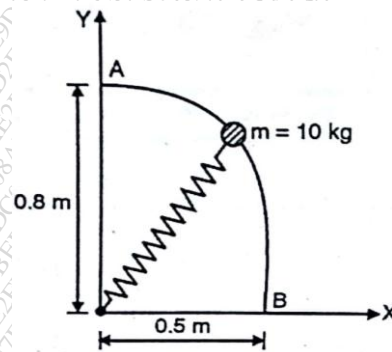

- c) A force of magnitude 50N acts along AB where A(2,1,0) and B(3,3,-1). Find the moment of this force about origin. [6]

Q4 a) A 10m long beam $ABCDE$ is supported and loaded as shown in the figure. Determine the value of W so that the reactions at A and D are equal. [8]

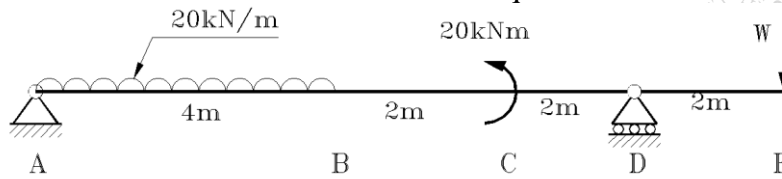

b) From the top of a tower 25m high (above ground) a ball is thrown up with a velocity of 50m/s at an angle of 30° with respect to horizontal. At what distance it would hit the ground from the foot of the tower. Also find the maximum height attained above ground and velocity with which it hits the ground. [6]

c) A wheel of radius 0.5m rolls without slipping on a horizontal stationary surface to the right. Determine the velocities of the points P and Q when the velocity of centre of the wheel is 20m/s to the right. [6]

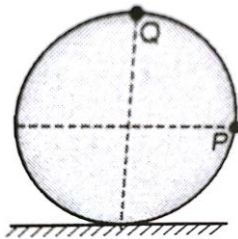

Q5a) For the truss shown in Fig, length of $BD=DE=8m$. Determine
 (i) Force in member BC by method of sections only. [2]
 (ii) Force in all other members by method of joints [6]

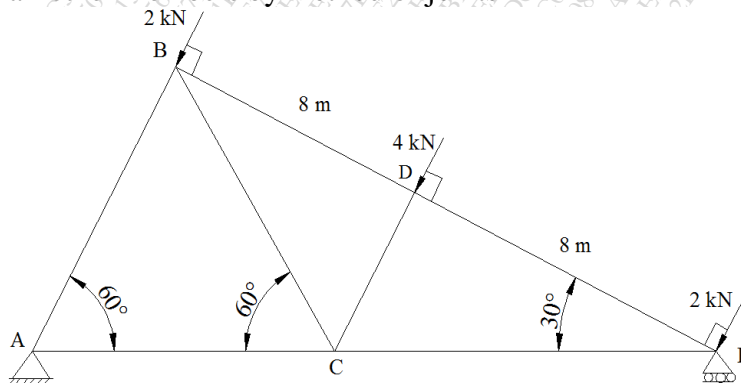

b) In a 100m Asian games event an athlete accelerates uniformly from the start to his maximum velocity in a distance of 4m and runs the remaining distance with that velocity. If the athlete completes the race in 10.4 sec, determine his initial acceleration and his maximum velocity. Also draw v-t graph and x-t graph for his motion. [6]

- c) In the slider crank mechanism shown in fig, the crank OA of length 200mm rotates anticlockwise with an angular velocity of 100rad/sec. The slider at B is constrained to move along a horizontal line. At the instant shown, find the angular velocity of connecting rod AB and velocity of slider at B. [6]

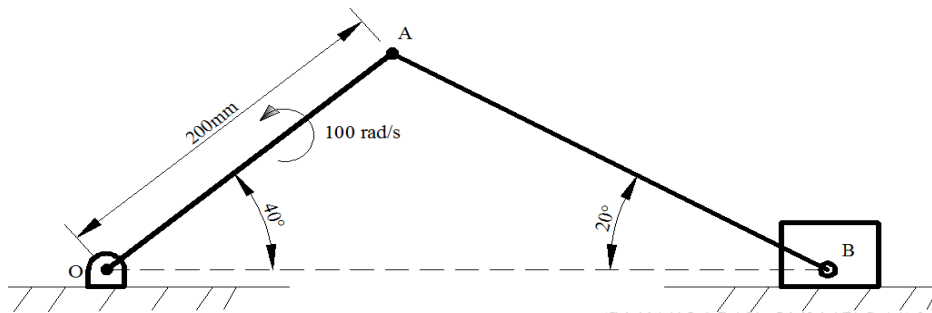

- Q6 a) Two identical blocks A & B are connected by rod & rest against vertically & horizontal planes resp. as shown in fig. If sliding impends when $\theta=45^\circ$, determine the coefficient of static friction (μ), assuming it to be same at both floor and wall. [8]

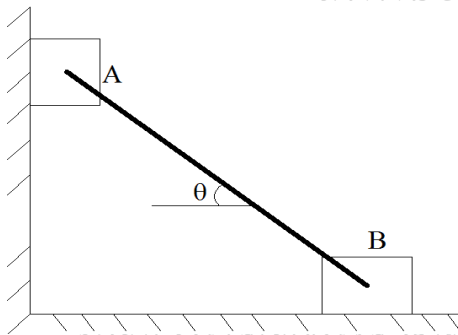

- b) The tripod shown in fig supports a vertical load $W=100\text{KN}$. Find the compressive force acting on each member. All joints are ball and socket type. [6]

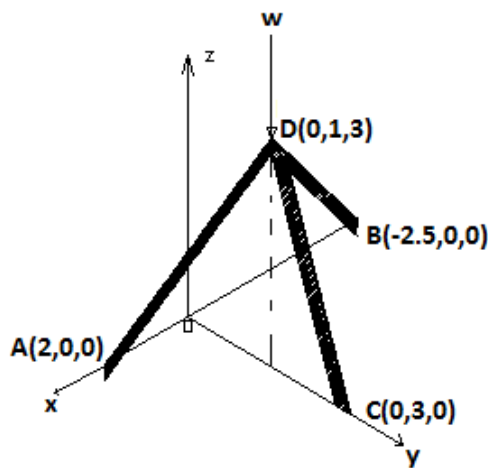

c) A particle moving along a curved path has a velocity of 3m/s and total acceleration 1.6m/s^2 when at point A. Acceleration at A is in the direction 20° to the tangent to the path at A. Determine the radius of curvature of the path at A.

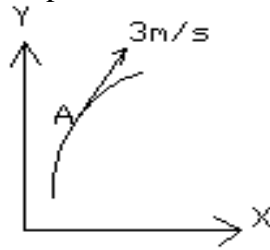

OR

c) Blocks A=150N and block B=200N are connected by inextensible string as shown in fig. Determine the accelerations of block A and block B. Pulleys are frictionless. [6]

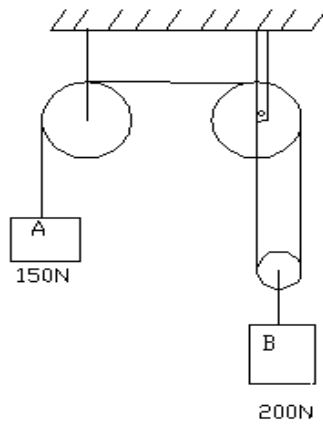

(3 Hours)

[Total Marks: 80]

NB. Q.1 is Compulsory.
Solve any three questions from the remaining
Assume suitable data if required and justify it.

- Q.1** a) State and explain superposition theorem 3
b) Find the equivalent resistance between A & B 3

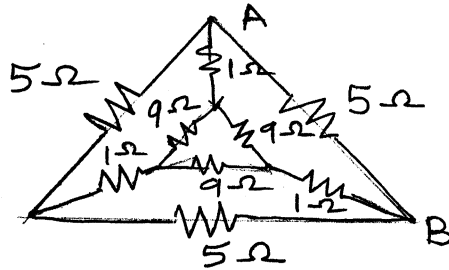

- c) Find average value of the shown waveform 3

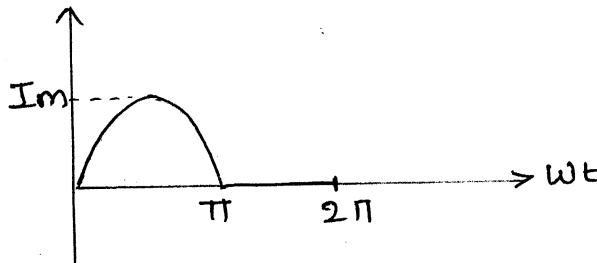

- d) Explain the working of 1-phase transformer & derive its emf equation 4
e) Derive the condition for resonance in series R-L-C circuit 4
f) Write the relation between line and phase quantities in case of star connected load and delta connected load 3

- Q.2** a) Find the current through 10Ω resistor by mesh analysis. 6

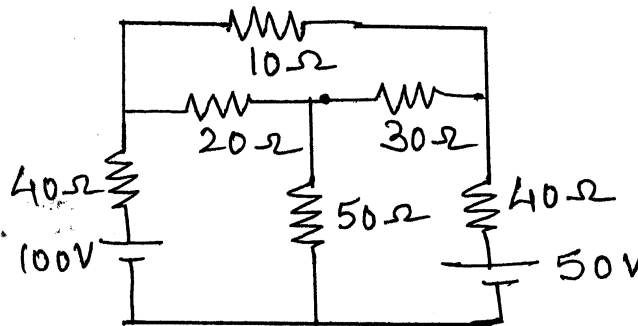

- b) A resistance is connected in series with a coil across 230V, 50 Hz supply. The current is 1.8 A and voltage across the resistance and coil are 80V, & 170V respectively. Calculate the resistance and inductance of the coil & phase difference between the current and supply voltage. Draw phasor diagram. 8
c) Explain open circuit test of a single phase transformer 6

TURN OVER

- Q.3**
- a) Three identical choke coils are connected as a delta load to a three-phase supply. The line current drawn from the supply is 15A and total power consumed is 7.5 KW. The KVA input is 10KVA. Find 8
- Line and phase voltage
 - Impedance /phase
 - Reactance/phase
 - Resistance/phase
 - Inductance if frequency is 50 Hz
 - P.f.
 - Phase current
- b) A single phase transformer has primary voltage of 230 V, No-load primary current is 5A. No-load p.f. is 0.25 ,number of primary turns is 200 and frequency is 50Hz.. calculate 6
- Maximum flux induced in the core
 - Core loss
 - Magnetizing current
- c) Explain the use of filter in a rectifier circuit 2
- d) Explain input characteristics of CE configuration 4

- Q.4**
- a) Reduce the circuit into a single current source in parallel with single resistance 5

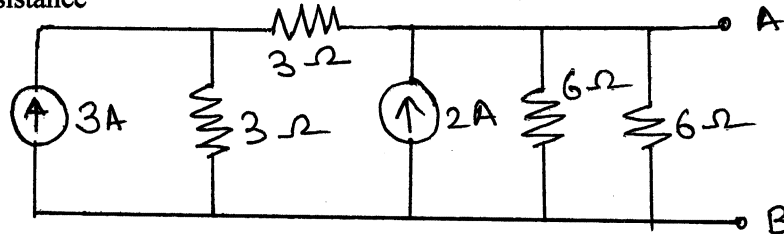

- b) Draw the phasor diagram for the circuit shown. Also find the values of current, V_1 , V_2 and power factor. 7

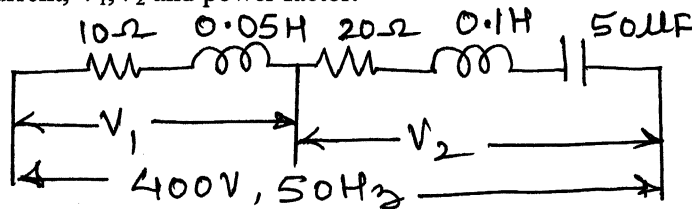

- c) Explain the effect of power factor on wattmeter reading. 4
- d) Explain the working of full wave bridge rectifier 4
- Q.5**
- a) Using Norton's theorem find current through 10 Ω branch 8

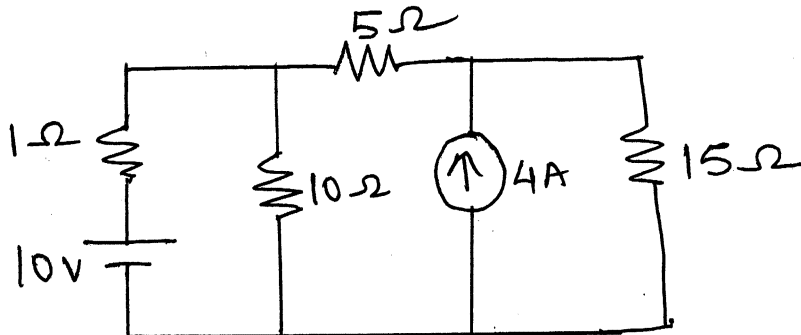

- b) Two impedances of $Z_1 = (10 + j15) \Omega$ and $Z_2 = (6 - j8) \Omega$ are connected in parallel across an ac supply. If load current supplied is 15A what is the power taken by each branch. 4
- c) A 25 KVA, 2200/220 V, 50 Hz, 1-phase transformer has a primary resistance of 1.8Ω . calculate the efficiency of the transformer at 8
- Full load unity power factor
 - Half load, 0.8 lagging power factor
- Iron loss is 1000 W

Q.6 a) find current through 5Ω branch using superposition theorem 7

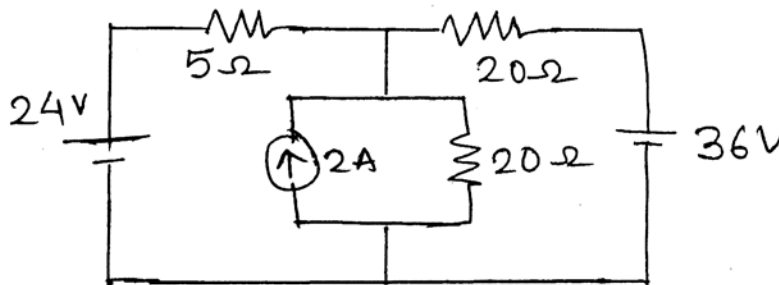

- b) R-L circuit of 2Ω and $0.01H$ is connected in series with a capacitor across 200V mains. Maximum current flows through the circuit at 50Hz frequency. What should be the value of capacitor. Also find value of current and voltage across capacitor 7
- c) Show that $W_1 + W_2 = P$ in a 3-phase star connected load. 6

[Time: 2 Hours]

[Total Marks: 60]

Please check whether you have got the right question paper.

- N.B:
1. Question no **1** is **compulsory**.
 2. Answer **any three** questions from remaining **five** questions.
 3. Figure to the right indicate full marks.
 4. Atomic weights : Ca = 40, Cl = 35.5 Mg = 24, C = 12, O = 16, H = 1.

- Q.1** Attempt **any five** from the following: **15**
- a) Explain the principal of EDTA method.
 - b) Explain vulcanization of rubber.
 - c) Define lubricant and give its functions.
 - d) State Gibb's phase rule and define phase.
 - e) What are nano materials?
 - f) Distinguish between thermoplastics and thermosetting plastics.
 - g) 20 ml of sewage water is refluxed with 0.1N $K_2Cr_2O_7$ in presence of H_2SO_4 and Ag_2SO_4 . The unreacted dichromate required 6ml of 0.1N FAS solution. Blank titration consumed 15ml of 0.1N FAS solution. Calculate COD of effluent.
- Q.2** a) Calculate the quantity of lime (90% pure) and (80% pure) required to soften one million litres of water containing $CaCl_2 = 22.2ppm$, $MgCl_2 = 9.5 ppm$, $CO_2 = 33ppm$, $HCl = 7.3ppm$ **06**
- b) With the help of phase diagram explain one component system. **05**
 - c) Describe laser method of preparation of CNT's. **04**
- Q.3** a) Define lubrication. Discuss the boundary film lubrication mechanism. **06**
- b) Write short note on injection moulding process. **05**
 - c) State the limitations of phase rule. **04**
- Q.4** a) Give the preparation, properties and uses of (any two) **06**
- a) PMMA b) Buna – S c) Kevlar
 - b) With the help of neat and labelled diagram explain zeolite process. **05**
 - c) 5ml of an oil takes 2.1ml of 0.02N KOH for titration. Find its acid value. **04**
(Density = 0.91 g1ml)

- Q.5** a) Write short notes on **06**
 i) Decay of concrete.
 ii) RCC
- b) Write short note on ‘Conducting Polymer.’ **05**
- c) The hardness of 10,000 litres of Hard water was removed by passing through zeolite. Zeolite required 5000 litres of NaCl solution containing 1170 mg NaCl / litre. Determine the hardness of water sample. **04**
- Q.6** a) With the help of flow sheet diagram explain activated sludge process. **06**
 b) Write notes on **05**
 i) Glass transition temp.
 ii) Polymers in medicine and surgery
- c) Explain the following properties of lubricants with significance. **04**
 i) Flash point and Fire point
 ii) Cloud point and pour point

Time : 2 Hours

Marks : 60

1. Question number 1 is compulsory
2. Attempt any three from remaining
3. Use suitable data wherever required
4. Figures to right indicate full marks.

Q.1) Solve any five from following

15

1. Draw the following with reference to a cubic unit cell: $(1\bar{0}\bar{2})$, $[211]$, $[\bar{1}\bar{1}\bar{1}]$
2. Define space lattice Basis & coordination number
3. Define Fermi energy level. Explain Fermi Dirac distribution function.
4. Write Sabine's formula explaining each term. Explain how this formula can be used for the determination of absorption coefficient of a given material.
5. Calculate the electronic polarizability of Ar. Given number of Ar atoms at NTP = $2.7 \times 10^{25}/\text{m}^3$ and dielectric constant of Ar = 1.0024.
6. Explain the statement "crystal act as three dimensional grating with x-rays".
7. In a magnetic material the field strength is found to be 10^6 A/m. If the magnetic susceptibility of the material is 0.5×10^{-5} . Calculate intensity of magnetization and flux density in the material.

Q.2) (a) With a neat labelled diagram explain the principle, construction and working of a piezoelectric oscillator.

8

(b) Molecular weight of silver bromide is 187.77. Its density is 6.473 gm/cm^3 . It has NaCl type structure. Calculate the distance between adjacent atoms.

Avogadro's No. = $6.023 \times 10^{23}/\text{gm. mole.}$

7

Q.3) (a). Draw the unit cell of HCP. Derive the number of atoms/unit cell, the c/a ratio and the packing fraction.

Estimate the number of Frenkel defects per mm^3 in AgCl if energy of formation of Frenkel defects is 1.5 eV at 700^0K . The molecular weight of AgCl is 0.143 kg/mol and specific density is 5.56.

8

(b) Explain Hall effect & its significance. With a neat diagram derive the expression for the Hall voltage & Hall coefficient.

7

Q.4) (a) For an intrinsic semiconductor show that the Fermi level lies in the centre of the forbidden energy gap 5

(b) Two ships are anchored at certain distance between them. An ultrasonic signal of 50 KHz is sent from one ship to another via 2 routes. First through water and second through atmosphere. The difference between the time intervals for receiving the signals at the other ship is 2 seconds. If the velocity of sound in atmosphere and seawater are 348 m/s and 1392 m/s respectively, find the distance between the Ships. Also find the time taken by the signal to travel through water. 5

(C) Explain the determination of the crystal structure using Braggs spectrometer. 5

Q. 5) (a) Explain in brief the different phases of liquid crystals. 5

(b) Two parallel plate capacitors having equal and opposite charges are separated by a dielectric slab of thickness 2 cm. If the electric field inside is 10^6 V and dielectric constant is 3, calculate the polarization and displacement density. 5

(c) Calculate the critical radius ratio of an ionic crystal for ligancy 6. 5

Q.6) (a). The volume of a room is 600 m^3 , the wall area, floor area and ceiling area respectively are 220 m^2 , 120 m^2 and 120 m^2 . The average sound absorption coefficient for the walls, floor and ceiling are 0.03, 0.06 and 0.8 respectively. Find the average sound absorption coefficient and the reverberation time. 5

(b) Explain principle construction & working of a LED. 5

(c) Prove that in a ferromagnetic material, power loss per unit volume in a hysteresis cycle is equal to the area under hysteresis loop. 5

Q.P. Code : 18491

[Time: 2 Hours]

[Marks: 60]

Please check whether you have got the right question paper.

- N.B:
1. Question.No.1 is compulsory.
 2. Attempt any three questions from Q. 2 to Q. 6
 3. Draw neat labelled diagrams wherever necessary.
 4. Figures to the right indicate full marks.

- Q. 1** Attempt **any five** from the following: (20)
- a) Explain the reasons for depletion of soil resources.
 - b) When it is necessary to obtain environmental consent?
 - c) What causes 'Acid-Rain'? What are its adverse effects?
 - d) Explain social aspects of Sustainable development.
 - e) Draw a suitable diagram and explain only working principle used in extraction of geothermal energy.
 - f) Why Solid Waste Management is essential?
 - g) Write effects produced by any three indoor air pollutants.
- Q. 2**
- a) Explain significance of the term 'Resource Utilization per Carrying Capacity', in the context of sustainable development. (05)
 - b) Draw a neat diagram of Venturi Scrubber and briefly explain its working. (05)
 - c) Draw a suitable diagram and explain the process of hydropower generation. (05)
- Q. 3**
- a) How ozone layer depletion takes place? What are its adverse effects? (05)
 - b) Write briefly important powers and functions of State Pollution Control Board (SPCB). (05)
 - c) Explain how the techniques of disaster management are implemented at the time of Tsunami. (05)
- Q. 4**
- a) What are the causes and impact of depletion of our natural water resources? (05)
 - b) Write important features of 'Environmental Protection Act'. (05)
 - c) Draw a neat diagram and explain working of flat plate collector. (05)
- Q. 5**
- a) Explain the role of appropriate technology for better sustainable development. (05)
 - b) Briefly explain the process of Industrial Waste Water treatment. (05)
 - c) Explain how energy is produced from wind, with the help of suitable diagram. (05)
- Q. 6**
- a) What are the global environmental problems pertaining to minerals. (05)
 - b) What causes E-pollution? What will be its impact? (05)
 - c) What role is played by technology for better human health and environment? (05)

(3 hours)

Total marks: 80

- N.B.:** (1) Question No. 1 is compulsory
(2) Attempt any Three from remaining

- Q1 a) If $\log \tan x = y$ then prove that $\sinh ny = \frac{1}{2} [\tan^n x - \cot^n x]$ [3]
 b) If $u = x^2y + e^{xy^2}$ Find $\frac{\partial^2 u}{\partial x \partial y}$ [3]
 c) If $x = u - uv$, $y = uv - uvw$, $z = uvw$ find $\frac{\partial(x,y,z)}{\partial(u,v,w)}$ [3]
 d) Using Maclaurin's series, Prove $e^{e^x} = e + ex + ex^2 + \dots$ [3]
 e) Show that $A = \begin{bmatrix} \alpha + i\gamma & -\beta + i\delta \\ \beta + i\delta & \alpha - i\gamma \end{bmatrix}$ is unitary [4]
 if $\alpha^2 + \beta^2 + \gamma^2 + \delta^2 = 1$
 f) Find n^{th} derivative of $\frac{x}{(x-1)(x-2)(x-3)}$ [4]

- Q2 a) Solve $x^5 = 1 + i$ and find the continued product of the roots. [6]
 b) Reduce the matrix $A = \begin{bmatrix} 5 & -6 & -6 \\ -1 & 4 & 2 \\ 3 & -6 & -4 \end{bmatrix}$ to the normal form [6]
 and find its Rank
 c) State and Prove Euler's theorem for two variables hence [8]
 find value of $x \frac{\partial u}{\partial x} + y \frac{\partial u}{\partial y}$ where $u = \frac{\sqrt{xy}}{\sqrt{x} + \sqrt{y}}$

- Q3 a) Test the consistency of [6]
 $2x - y - z = 2$, $x + 2y + z = 2$, $4x - 7y - 5z = 2$
 And Solve if consistent.
 b) Examine the function for its extreme values [6]
 $f(x, y) = y^2 + 4xy + 3x^2 + x^3$
 c) If $\sin(\theta + i\phi) = e^{i\alpha}$ then Prove $\cos^4 \theta = \sin^2 \alpha = \sinh^4 \phi$ [8]

- Q4 a) If $x = u \cos v$, $y = u \sin v$ then [6]
 Prove $\frac{\partial(u,v)}{\partial(x,y)} \cdot \frac{\partial(x,y)}{\partial(u,v)} = 1$
 b) If $\log(x + iy) = e^p (\cos q + i \sin q)$ then [6]
 prove that $y = x \tan(\tan q \cdot \log \sqrt{x^2 + y^2})$
 c) Solve by Gauss Elimination method [8]

$$2x + 3y + 4z = 11, \quad x + 5y + 7z = 1, \quad 3x + 11y + 13z = 25$$

- Q5 a) Prove $\cos^6 \theta + \sin^6 \theta = \frac{1}{8} [3 \cos 4\theta + 5]$ [6]
 b) Evaluate $\lim_{x \rightarrow 0} \left[\frac{1}{x^2} - \cot^2 x \right]$ [6]
 c) If $y = \cos(m \sin^{-1} x)$ then [8]
 prove that $(1 - x^2)y_{n+2} - (2n + 1)x y_{n+1} + (m^2 - n^2)y_n = 0$

- Q6 a) Check if the following vectors [6]
 $X_1 = [1, 0, 2, 1], X_2 = [3, 1, 2, 1], X_3 = [4, 6, 2, -4],$
 $X_4 = [-6, 0, -3, -4]$ are linear dependent hence find the relation
 between them if any.
 b) If $f(xy^2, z - 2x) = 0$ then [6]
 prove that $2x \frac{\partial z}{\partial x} - y \frac{\partial z}{\partial y} = 4x$
 c) Fit a second degree parabola $y = ax^2 + bx + c$ to the following data [8]

x	1	2	3	4	5	6	7	8	9
y	2	6	7	8	10	11	11	10	9