

(3 Hours)

[Total Marks: 80]

- N.B.: 1) Question No. 1 is Compulsory.
 2) Answer any THREE questions from Q.2 to Q.6.
 3) Figures to the right indicate full marks.

1) a) If $A = \begin{bmatrix} 2 & 4 \\ 0 & 3 \end{bmatrix}$ then find the eigen values of $6A^{-1} + A^3 + 2I$ [05]

b) Determine whether the given vectors $u = (-4, 6, -10, 1), v = (2, 1, -2, 9)$ are orthogonal with respect to the Euclidean inner product [05]

c) The probability density function of a random variable x is zero except at $x = 0, 1, 2$ and $p(0) = 3\alpha^3, p(1) = 4\alpha - 10\alpha^2, p(2) = 5\alpha - 1$. Find α [05]

d) Evaluate $\oint_c \frac{z+6}{z^2-4} dz$ where c is (i) $|z|=1$ (ii) $|z-2|=1$. [05]

2) a) Using Rayleigh-Ritz method, find an appropriate solution for the extremal of the functional $I = \int_0^1 [2xy - y^2 - y'^2] dx$ given $y(0)=y(1)=0$ [06]

b) Using Cauchy's Residue theorem evaluate $\int_0^{2\pi} \frac{d\theta}{5 + 4 \cos \theta}$ [06]

c) A random variable X has the probability distribution given below:

$X=x$	-2	3	1
$P(X=x)$	1/3	1/2	1/6

Find i) the moment generating function ii) the first four moments about the origin [08]

3) a) Compute $A^9 - 6A^8 + 10A^7 - 3A^6 + A + I$ where $A = \begin{bmatrix} 1 & 2 & 3 \\ -1 & 3 & 1 \\ 1 & 0 & 2 \end{bmatrix}$ [06]

b) Verify Cauchy-Schwartz inequality for the vectors $u = (-4, 2, 1)$ & $v = (8, -4, -2)$ [06]

c) Obtain Taylor's or Laurent's series expansion of the function $f(z) = \frac{1}{z^2 - 3z + 2}$ when (i) $|z| < 1$ (ii) $1 < |z| < 2$ [08]

- 4) a) Obtain the equation of the line of regression of Y on X for the following data and estimate Y when X = 73 [06]

X	70	72	74	76	78	80
y	163	170	179	188	196	200

- b) Show that the functional $\int_{x_1}^{x_2} [y^2 + x^2 y'] dx$ assumes extreme values on the straight line $y = x$ [06]

- c) Let R^3 have the Euclidean inner product. Use the Gram-Schmidt process to transform

the basis vectors $u_1=(1,0,0), u_2=(3,7,-2), u_3=(0,4,1)$ into an orthonormal basis [08]

- 5) a) Evaluate $\oint_c \frac{1}{z} \cos z dz$ where c is the ellipse $9x^2 + 4y^2 = 1$ [06]

- b) Seven dice are thrown 729 times. How many times do you expect at least four 10 dice to show three or five? [06]

- c) Show that the matrix $A = \begin{bmatrix} -9 & 4 & 4 \\ -8 & 3 & 4 \\ -16 & 8 & 7 \end{bmatrix}$ is diagonalisable. Find the diagonal form D and the diagonalising matrix M. [08]

- 6) a) A continuous random variable X has the p.d.f. defined by $f(x) = A + Bx, 0 \leq x \leq 1$. If the mean of the distribution is $\frac{1}{3}$ find A and B [06]

- b) Find e^A , if $A = \begin{bmatrix} 3 & 1 \\ 2 & 2 \\ 1 & 3 \\ 2 & 2 \end{bmatrix}$ [06]

- c) Evaluate $\int_{-\infty}^{\infty} \frac{x^2 dx}{(x^2 + a^2)(x^2 + b^2)}$ ($a > 0, b > 0$) [08]

(3 Hours)**[Total Marks: 80]**

- N.B. (1) Question No. 1 is compulsory.
 (2) Solve any **three** questions from remaining **five** questions.
 (3) **Figures** to the right indicate **full marks**.
 (4) Assume suitable data if necessary and mention the same in answer sheet.
1. (a) State biasing techniques of Enhancement Type MOSFET and explain any one technique in detail. **05**
 (b) Explain Transformer Coupled Amplifier and give its Advantages and Disadvantages. **05**
 (c) Define efficiency for a Power Amplifier and write the expression for the same. State the efficiency of Class A, Class B and Class C Amplifiers respectively. **05**
 (d) Give the basic principle of an Oscillator. State the types of Oscillators. **05**
 2. (a) Design a two stage RC coupled CS – CE Amplifier to meet following specifications: **15**
 $A_v \geq 750$, $S \leq 10$, $R_i \geq 1 \text{ M}\Omega$, $V_{cc} = 10 \text{ V}$.
 Assume the following data: $\beta_{\text{typ}} = 290$, $h_{ie} = 4.5 \text{ k}\Omega$, $g_{m0} = 5000 \mu\text{S}$, $I_{DSS} = 7 \text{ mA}$,
 $r_d = 50 \text{ k}\Omega$, $V_p = -4 \text{ V}$.
 (b) List various negative feedback topologies. Sketch any one topology. **05**
 3. (a) Sketch Circuit Diagram, AC equivalent Model and Derive expressions for Input impedance, Output Impedance, Voltage Gain and Current Gain of a two stage CE Amplifier. **10**
 (b) For a 'n' stage cascaded amplifier, show that overall lower 3 dB cut – off frequency is **10**
 $f_{LT} = \frac{f_L}{\sqrt{2^{1/n} - 1}}$ and overall higher frequency is $f_H' = f_H(\sqrt{2^{1/n} - 1})$.
 4. (a) Draw a neat diagram of Class AB power Amplifier and explain its working. **10**
 (b) What is Cascode Amplifier? Explain in detail. **10**
 5. (a) Draw RC phase shift oscillator using BJT and derive the frequency of oscillation for same. **10**
 (b) Enumerate the effects of negative feedback on Gain, Bandwidth, Distortion, Input and Output Impedance. **10**
 6. (a) Compare Small Signal and Large Signal Amplifier. **05**
 (b) Calculate frequency of Oscillation for Hartley Oscillator if $L_1 = 5 \text{ mH}$, $L_2 = 2 \text{ mH}$ and $C = 0.5 \mu\text{F}$. **05**
 (c) Explain the concept of Heat Sink in detail required for Power Amplifiers. **05**
 (d) Sketch Symbol of n-channel and p-channel Depletion MOSFET. State giving reasons, why it is known as depletion MOSFET? **05**

(3 Hours)

Marks: 80

- N.B. :** (1) Question No. 1 is compulsory.
 (2) Solve any three questions from the remaining five
 (3) Figures to the right indicate full marks
 (4) Assume suitable data if necessary and mention the same in answer sheet.

Q.1 Attempt the questions.

- a) In the circuit given in Fig. 1(a) if the voltage V_+ and V_- are to be amplified by the same factor, the value of R should be _____ [01]
 i) 3.3k ii) 33k iii) 330 Ω iv) None of these. [04]

Justify.

- b) If the input to the ideal comparator shown in Fig. 1(b) is a sinusoidal signal of 8 volt peak to peak without any DC component, then the duty cycle of the output comparator is _____ [01]
 i) 33.33% ii) 25% iii) 20% iv) None of these. [04]

Justify.

- c) What is the frequency of IC 555 astable multivibrator shown in Fig. 1(c)? [01]
 i) 241 Hz ii) 178 Hz iii) 78 Hz iv) 8 Hz. [04]

Justify.

- d) An amplifier using OPAMP with slew rate $SR = 1 \text{ V}/\mu\text{s}$ has a gain of 40 dB. If this amplifier has to amplify sinusoidal signal of 20 kHz faithfully without any slew rate induced distortion, then the input signal must not exceed _____ [01]
 i) 795 mV ii) 395 mV iii) 79.5 mV iv) 39.5 mV. [04]

Justify.

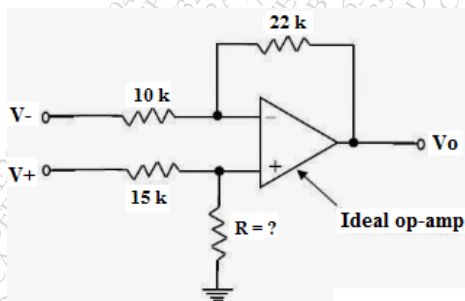

Fig. 1(a)

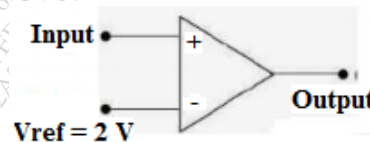

Fig. 1(b)

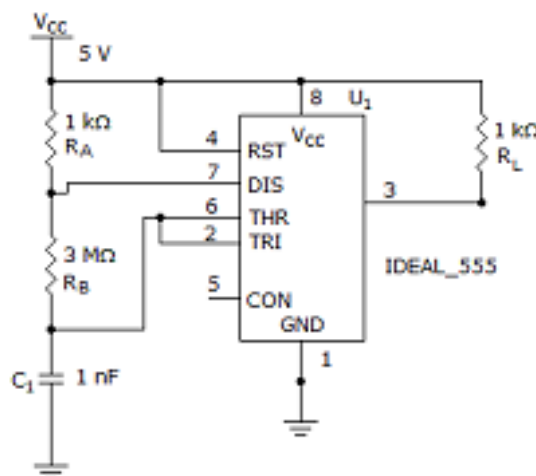

Fig. 1(c)

- Q.2** a) Sketch the implementation of an instrumentation amplifier using three opamps and explain its operation. [10]
- b) Compare ideal and practical opamp. [5]
- c) Explain current foldback protection in voltage regulators. [5]
- Q.3** a) Design a Schmitt trigger circuit to convert 5V, 1kHz sinusoidal signal to square wave using 741IC, $V_{UT} = 0.8\text{ V}$, $V_{LT} = -0.8\text{ V}$ and $\pm V_{sat} = \pm 11\text{ V}$. Draw its transfer characteristics, input and output waveforms. [10]
- b) With the help of circuit diagram, derive the expression of output analog voltage for a weighted resistor DAC. [10]
- Q.4** a) Design an IC 555 astable multivibrator for an output frequency 1 kHz and a duty cycle of 60%. [10]
- b) With the help of a functional block diagram explain the working of voltage regulator LM317 to give an output voltage variable from 6 V to 12 V to handle maximum load current of 500 mA. [10]
- Q.5** a) Design a Wein Bridge oscillator using opamp to oscillate at a frequency of 965 Hz and explain the working of Wein bridge oscillator. [10]
- b) List and explain the various performance parameters of DAC. [10]
- Q.6 Short notes on: (Attempt any four)** [20]
- a) Comparison of linear and switching regulators.
- b) Active filters using opamp
- c) Precision rectifiers
- d) PLL IC 565
- e) Widlar current source

3 Hours

Total marks: 80

- Question no. 1 is compulsory
- Attempt any Three questions from remaining

Q1. Answer any 4 questions from the given questions:

20

- If system matrix $A = \begin{bmatrix} -3 & 1 \\ -2 & 0 \end{bmatrix}$ find the state transition matrix.
- Find the fundamental frequency of the signal

$$x(t) = \cos\left(\frac{10\pi}{3}t\right) + \sin\left(\frac{5\pi}{4}t\right)$$
- Explain the application of Signals and System in Multimedia Processing.
- Express the signals shown in Fig 1 in terms of unit step function

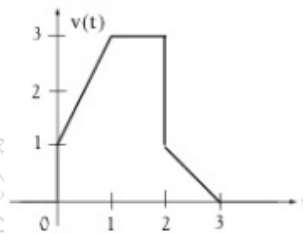

Fig. 1

- Explain Energy and power of a signal.
- Test the given system for linearity, causality, stability, memory and time variant.

$$y(t) = x(t^2)$$
- Explain the application of Signals and System in Multimedia Processing.

Q2. Evaluate $y(t) = x(t) * h(t)$, where $x(t) = u(t) - u(t-3)$ and $h(t) = u(t) - u(t-2)$
 (a) by an analytical technique, and (b) by a graphical method.

20

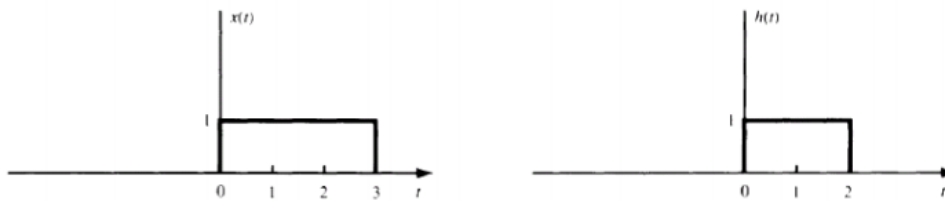

Q3.a. Determine the sequence $x[n]$ associated with Z-Transform using residue method.

10

$$X(z) = \left\{ \frac{(1-e^{-a})z}{(z-1)(z-e^{-a})} \right\}$$

b. State and Prove Parseval's Theorem with respect to DTFT.

10

Q4.a. Determine the state model of the system governed by the equation

10

$$y[n] = -2y[n-1] + 3y[n-2] + 0.5y[n-3] + 2x[n] + 1.5x[n-1] + 1.5x[n-2] + 4x[n-3]$$

b. Find Fourier series for $f(x) = x^3(-\pi, \pi)$

10

Q5.a Determine DTFS for the sequence $x(n) = \cos^2((\pi/8)n)$

8

b. Find Laplace transform of $\frac{d}{dt} \sin(t) u(t)$.

8

c. Find Inverse Laplace transform using convolution

4

$$L^{-1} = \left\{ \frac{s^2}{(s^2 + a^2)(s^2 + b^2)} \right\}$$

Q6. Write short note on any two:

20

a. Feedforward Control system

b. ROC in Z-Transform and Laplace Transform

c. Relation of ESD, PSD with auto-correlation

Time 3 Hrs.

Total Marks: 80

- Instructions: 1) Question Number 1 is compulsory.
2) Attempt any three from remaining questions.
3) Use suitable data whenever is required.

- Q1 Solve **Any Four** 20 Marks
- a Compare FM and AM.
 - b Explain the necessity of De-emphasis and pre-emphasis in Frequency Modulator.
 - c Define and explain Selectivity and Sensitivity for Radio Receiver.
 - d What is Aliasing? How it can be prevented?
 - e What is Time Division Multiplexing? Also give its applications.
- Q2
- a Explain balanced modulator using diode for the generation of DSBSC AM signal. 10 Marks
 - b How to Generate SSB using filter method? 10 Marks
- Q3
- a List types of noise and explain any four types of internal noise. 5 Marks
 - b What do you mean by Noise factor and noise figure. How it can be improved? 5 Marks
 - c Draw the block diagram of super- heterodyne receiver and explain the operation. Write frequency components present at the output of each block if audio frequency is 1 KHz and carrier frequency is 540 KHz 10 Marks
- Q4
- a With the help of neat diagram and waveforms explain generation and demodulation of Pulse position modulation 10 Marks
 - b A carrier wave of frequency 100 MHz is frequency modulated by sine wave of amplitude 20 volts and frequency 100 KHz. The frequency sensitivity of the modulation is 25 KHz per volt. Determine the approximate bandwidth of FM wave using Carson's rule. 5 Marks
 - c A 360 W carrier is simultaneously Amplitude modulated by two audio waves with modulation percentages of 55 and 65 respectively. What is the total sideband power 5 Marks
- Q5 Write Short note on (**Any Four**) 20 Marks
- a Frequency Division Multiplexing
 - b Double Spotting and Fidelity of Radio Receiver
 - c Wide Band and Narrow Band FM
 - d Applications of pulse communication
 - e ISB Receiver
- Q6
- a Describe Foster-seeley Discriminator with a neat circuit diagram and explain its principle with necessary Equations. What are its merits and Demerits? 10 Marks
 - b Explain generation of Frequency Modulated wave using Armstrong Method 10 Marks
