

Q1.	Choose the correct options for following questions. All the Questions are compulsory and carry equal marks. 2 marks each.
1.	The value of $\beta\left(\frac{5}{2}, \frac{3}{2}\right)$ is equal to
Option A:	$\sqrt{\pi}$
Option B:	$\sqrt{2\pi}$
Option C:	π
Option D:	$\pi/16$
2.	The solution of differential equation $\frac{d^2y}{dx^2} + 4\frac{dy}{dx} + 4y = 0$ is
Option A:	$(c_1 + c_2x)c_3xe^{-x}$
Option B:	$(c_1 + c_2x)e^{-2x}$
Option C:	$(c_1 + c_2x)e^{2x}$
Option D:	$(c_1 + c_2x)c_3xe^x$
3.	Particular Integral (P.I.) of differential equation $(D^3 - 3D^2)y = e^{4x}$ is
Option A:	$P.I. = \frac{1}{16}e^{-4x}$
Option B:	$P.I. = \frac{1}{64}e^{-4x}$
Option C:	$P.I. = \frac{1}{16}e^{4x}$
Option D:	$P.I. = \frac{1}{64}e^{4x}$
4.	Value of the integral $\int_0^\infty \int_0^\infty \int_0^\infty e^{-(x+y+z)} dx dy dz$ is
Option A:	∞
Option B:	0
Option C:	1
Option D:	-1
5.	The value of $\int_0^1 \int_0^{\pi/2} r \sin\theta dr d\theta$ is
Option A:	$\frac{1}{2}$
Option B:	$\pi/2$
Option C:	$1/8$
Option D:	$\pi/8$
6.	Integrating factor of $(12y + 4y^3 + 6x^2)dx + 3(x + xy^2)dy = 0$ is
Option A:	x^3
Option B:	x^2
Option C:	$\log x$
Option D:	e^x
7.	The Value of $\int_0^\infty e^{-x^4} dx$ is given by
Option A:	$\Gamma\left(\frac{1}{4}\right)$
Option B:	$\frac{1}{4}\Gamma\left(\frac{3}{4}\right)$
Option C:	$\frac{1}{4}\Gamma\left(\frac{1}{4}\right)$
Option D:	$\Gamma\left(\frac{3}{4}\right)$

8.	The value of $I = \int_0^1 \int_0^1 \int_0^1 x y z dx dy dz$ is given by
Option A:	$-\frac{1}{8}$
Option B:	$\frac{1}{4}$
Option C:	$-\frac{1}{4}$
Option D:	$\frac{1}{8}$
9.	The value of $I = \int_0^1 \int_0^x (x^2 + y^2) x dy dx$ is

Option A:	$\frac{3}{35}$
Option B:	$\frac{3}{15}$
Option C:	$\frac{1}{35}$
Option D:	$\frac{4}{15}$
10.	Length of the curve $y = \log \cos x$ from $x = 0$ to $x = \frac{\pi}{3}$ is
Option A:	$\log(1 + \sqrt{2})$
Option B:	$\log(2 + \sqrt{3})$
Option C:	$\log 2$
Option D:	$\log 5$

Q2 (20 Marks Each)	Solve any Four out of Six	5 marks each
A	Using Beta function, Prove that $\int_0^{\infty} \frac{1}{1+x^2} dx = \frac{\pi}{2}$	
B	Using the method of variation of parameters, solve $\frac{d^2y}{dx^2} + a^2y = \sec ax$	
C	Show that the area between the parabolas $y^2 = 4ax$ and $x^2 = 4by$ is $\frac{16}{3} ab$.	
D	Solve $y dx + x(1 - 3x^2y^2) dy = 0$	
E	Evaluate $\int_1^e \int_1^{\log y} \int_1^{e^x} \log z dz dx dy$	
F	Find the perimeter of the cardioid $r = a(1 - \cos\theta)$	

Q3 (20 Marks Each)	Solve any Four out of Six	5 marks each
A	Solve $(D^3 - 2D^2 + D)y = x^2 + x$	
B	Using beta and gamma function evaluate $\int_0^2 x^2 (2-x)^3 dx$	
C	Change the order of integration for the integral and evaluate $\int_0^{\infty} \int_0^x x e^{\frac{-x^2}{y}} dx dy$	
D	Solve $(x^2y - 2xy^2)dx - (x^3 - 3x^2y)dy = 0$	
E	Express into polar form and evaluate the integral $I = \int_0^a \int_0^{\sqrt{a^2-x^2}} e^{-(x^2+y^2)} dx dy$	
F	Evaluate the integral $\int_0^1 \int_0^{\sqrt{1-x^2}} \int_0^{\sqrt{1-x^2-y^2}} \frac{1}{\sqrt{1-x^2-y^2-z^2}} dx dy dz$.	

Q4 (20 Marks Each)	Solve any Four out of Six	5 marks each
A	Solve the following differential equation $y \frac{dy}{dx} + \frac{4x}{3} - \frac{y^2}{3x} = 0$	
B	Change to polar co-ordinates and evaluate $\int_0^1 \int_0^x x + y \, dy dx$	
C	Solve $(D^2 + 4)y = \cos 2x$	
D	Evaluate using DUIS $\int_0^\infty \frac{\log(1+ax^2)}{x^2} dx$	
E	Evaluate the integral $\int \int \int \sqrt{x^2 + y^2} \, dx \, dy \, dz$ over the region bounded by $x^2 + y^2 = z^2, z > 0$ and $z = 0, z = 1$.	
F	Evaluate $\int_0^\pi \cos^3 3\theta \sin^2 6\theta \, d\theta$	

University of Mumbai
Examination 2020 under cluster __ (Lead College: _____)

Examinations Commencing from 28 June 2022 to 14 July 2022

Program: ALL

Curriculum Scheme: Rev2016

Examination: FE Semester II

Course Code: FEC202 and Course Name: Applied Physics-II

Time: 2 hour

Max. Marks: 60

Q1. (12 marks)	Choose the correct option for following questions. All the Questions are compulsory and carry equal marks - 2 marks each
1.	The penetration of waves into the regions of the geometrical shadow is
Option A:	Interference
Option B:	Diffraction
Option C:	Polarization
Option D:	Dispersion
2.	Holography records
Option A:	Interference
Option B:	Diffraction
Option C:	Amplitude and phase
Option D:	Wave length
3.	The numerical aperture of a fiber with core refractive index $n_1=1.61$ & cladding index $n_2=1.55$ is
Option A:	0.235
Option B:	0.435
Option C:	0.123
Option D:	0.534
4.	----- transformation are replaced by the Lorentz transformation which confirms the postulate of relativity
Option A:	Galilean
Option B:	Maxwell
Option C:	Planck's
Option D:	Newton's
5.	Which of the following is not an example of bottom-up approach for the preparation of nanomaterial's
Option A:	Sol-Gel
Option B:	Molecular self-assembly
Option C:	Mechanical grinding
Option D:	Chemical Vapour Deposition
6.	An example of magneto static focusing is
Option A:	Electron microscope
Option B:	Electron gun
Option C:	Anode
Option D:	Cathode

Q2 (16Marks)	Solve any Four out of Six	4 marks each
A	Define Resolving Power? Obtain expression for resolving power of grating.	
B	Calculate the angle at which the first dark band and next bright band are observed in Fraunhofer diffraction pattern due to a 0.3mm wide slit for wavelength 5890A.	
C	Explain construction and working of resonant cavity in the operation of laser.	
D	Explain the construction and working of a Transmission Electron microscope with a schematic diagram.	
E	Write expression for divergence of a vector quantity and explain its significance.	
F	State Maxwell's all four equations and give the significance of each.	

Q3. (16 Marks)	Solve any Four out of Six	4 marks each
A	Prove that in Newton's ring experiment radius is dark ring is proportional to square root of natural number.	
B	In Newton's rings experiment the diameter of 10 th ring on reflection reduces from 1.40 to 1.27 cm when a liquid is introduced between the lens and the plate. Find the refractive index of the liquid	
C	What is mode of propagation? Distinguish between single mode & multimode propagation?	
D	With neat block diagram explain construction and working of CRO.	
E	What is curl of a vector? Explain its significance	
F	Draw the schematic diagram of Scanning Electron Microscope and explain its construction, working, advantages, disadvantages and applications.	

Q4. (16 Marks)	Solve any Four out of Six	4 marks each
A	Explain the construction and working of He -Ne laser with energy level diagram?	
B	Find gradient of scalar field $A=3x^2y-y^3z^3$ at point (1,-2,-1)	
C	Write short note on electrostatic focusing & Magneto static focusing	
D	Describe any two methods to synthesize Nanomaterial's	
E	What is the highest order spectrum, which may be seen with monochromatic light of wavelength 6000 Å by means of a diffraction grating with 5000 lines/cm?	
F	Explain the thin film as highly-reflection coating.	

University of Mumbai

Curriculum Scheme: Rev2016

All Programs

Examination: FE Semester II_FH2022

Course Code: FEC203

Course Name: Applied Chemistry II

Time: 2 hour

Max. Marks: 60

Note: Atomic Weights – H-1, C-12, N-14, O-16, S-32, Cl-35.5

Q1.	Choose the correct option for following questions. All the Questions are compulsory and carry equal marks (2 marks each)
1.	The chemical reaction is not considered as green reaction when _____
Option A:	Renewable feedstock is used
Option B:	% Atom economy is high
Option C:	Catalyst is used
Option D:	Products are not biodegradable
2.	Aluminium gets less corroded than iron because _____
Option A:	Aluminium does not react with oxygen
Option B:	Aluminium is lighter than iron
Option C:	Aluminium forms stable nonporous oxide film
Option D:	Aluminium has large particle size than iron
3.	Wood's metal is an alloy of _____
Option A:	Lead
Option B:	Silver
Option C:	Zinc
Option D:	Copper
4.	LPG comes under category _____
Option A:	Primary liquid fuel
Option B:	Secondary liquid fuel
Option C:	Primary gaseous fuel
Option D:	Secondary gaseous fuel
5.	What is the amount of oxygen required for complete combustion of 1 kg of carbon?
Option A:	2.67 g
Option B:	2.67 kg
Option C:	1 kg
Option D:	2 kg
6.	Kevlar is an example of _____
Option A:	Glass fibres
Option B:	Carbon fibres
Option C:	Aramid fibres

Option D:	whiskers
-----------	----------

Q2	Solve any Four Questions out of Six	4marks each
A	With the help of neat diagram and reactions explain the mechanism of electrochemical corrosion with evolution of hydrogen.	
B	A gas has following composition by volume: CH ₄ = 40%, CO = 12%, H ₂ = 40%, N ₂ = 3%, CO ₂ = 3% and O ₂ = 2%. Calculate the volume of air required for complete combustion of 1 m ³ of fuel.	
C	a) Write effect of pH of medium on rate of corrosion. b) State any four principles of green Chemistry.	
D	Write a short note on structural composites.	
E	Explain the effect of alloying on steel with Nickel and Tungsten.	
F	Explain significance of proximate analysis of coal.	

Q3	Solve any Four Questions out of Six	4marks each
A	List any four constituents of Paint and write one function of each of them.	
B	Calculate % atom economy for the production of hydrogen? $\text{C}_6\text{H}_{10}\text{O}_5 + 7\text{H}_2\text{O} \rightarrow 6\text{CO}_2 + 12\text{H}_2$	
C	Describe Kjeldahl's method for determination of nitrogen.	
D	Define shape memory alloy and write its two properties and two uses.	
E	a) Write any four characteristics of composite materials. b) Calculate % of sulphur in 2g coal if weight of BaSO ₄ obtained in Bomb calorimeter experiment is 0.125 g	
F	Explain how purity of metal and proper designing help in controlling corrosion.	

Q4	Solve any Four Questions out of Six	4 marks each
A	Describe sacrificial anode method of cathodic protection. Give any two advantages of the method over impressed current method.	
B	Define Cracking. Write any three advantages of catalytic cracking over thermal cracking.	
C	Explain concept of Stress corrosion and Pitting corrosion with the help of one example each.	
D	0.2 gm of coal sample was burnt in combustion apparatus. The increase in the weights of KOH bulb and CaCl ₂ tube are 0.56 gm and 0.05 gm respectively. Calculate the percentage of Carbon and Hydrogen in the coal sample.	
E	Give traditional route for Indigo dye preparation. Suggest with reasoning green route for its preparation.	
F	Give composition & uses of (Any two) i) Gun metal ii) Duralumin iii) German silver	

PAPER CODE : 29706

Duration - 3 Hours

Total marks - 60

NOTE:

- a. Use First Angle method of projections only.
- b. Use your judgement for any unspecified dimension.
- c. Retain all construction lines.
- d. Figures to the right indicate full marks.
- e. All dimensions are in mm.
- f. Show necessary dimensions.

Q1) Solve any one questions out of two (10)

- a) A line AB 70 mm long, has its end A 20 mm above the H.P. and 25 mm in front of V.P. The end B is 40 mm above the H.P. and 65 mm in front of the V.P. Draw the projections of AB and show its inclinations with the H.P. and V.P.
- b) An in-elastic string, of 125 mm length, is wound round a cylinder of 46 mm diameter, keeping the string always tight. Draw the curve generated by end point of string. Name the curve.

Q2) Solve any one questions out of two (15)

- a) A cylinder of diameter 50 and axis 70 mm long is resting on a point of its base on H.P. with axis inclined at 40° to H.P. The top view of the axis is inclined at 40° to XY line. Draw the projections of cylinder.
- b) A cone diameter of base 70 mm and height of axis 80 mm is resting on a point of its base circle on H.P. with the axis making 30° with the V.P. The front view of the axis is inclined at 40° to XY line. Draw the top view and Front view.

Q3) Solve any one questions out of two (15)

- a) Draw isometric view of an object whose views are shown in Figure.

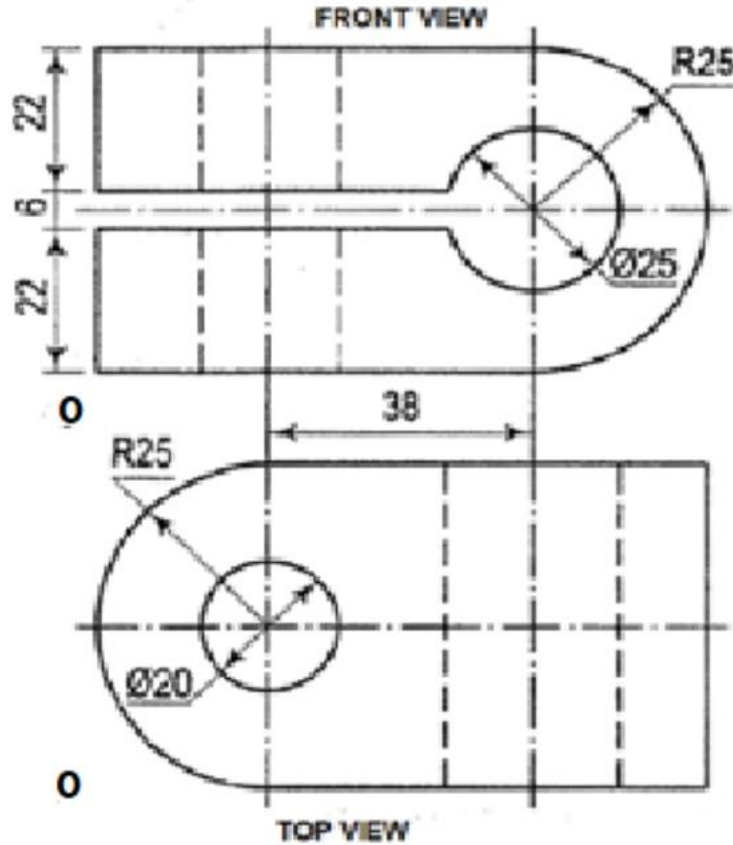

b) A pentagonal pyramid, base edges 25 mm and axis length 50 mm long has one of its triangular faces in the V.P. and edge of the base contained by that face makes an angle of 30° with H.P. Draw its projections.

Q4) For the object shown in figure draw the following views (20)

- (i) Sectional front view along section A-A.
- (ii) Top view
- (iii) Left hand Side View
- (iv) Insert the major dimensions

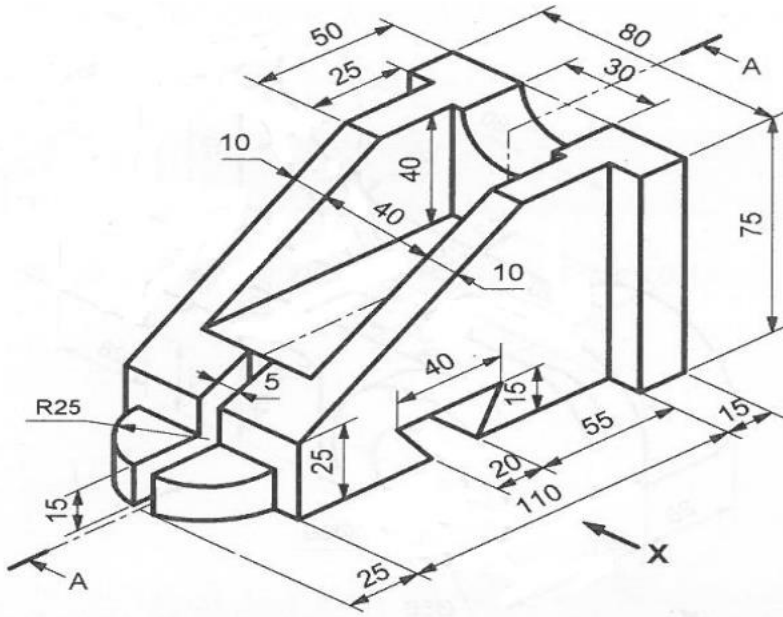

4DD3A35D804753A323ABAA9EFFB88DF6

University of Mumbai
Curriculum Scheme: Rev 2016

All Programs

Examination: FE Semester II _FH2022

Course code: FEC205

Course Name: Structured Programming Approach

Time: 2 Hr 30 Mins

Max. Marks: 80

Q1.	Choose the correct option for following questions. All the Questions are compulsory and carry 2 marks each.
1.	Which among the following is a Conditional Operator in C ?
Option A:	?:
Option B:	:?
Option C:	<=
Option D:	>=
2.	Which storage class is called as default storage class?
Option A:	auto
Option B:	register
Option C:	static
Option D:	extern
3.	Which among the following is an exit controlled loop?
Option A:	for
Option B:	while
Option C:	do...while
Option D:	if ...else
4.	In the following initialization what is value of A[5] ? int A[10] = {9, 8, 7, 6, 5, 4, 3, 2, 1, 0};
Option A:	5
Option B:	4
Option C:	3
Option D:	2
5.	Recursion is a process in which a function calls _____.
Option A:	Itself
Option B:	another function
Option C:	main() function
Option D:	sub program
6.	Which data type is best for storing a number 65000 in a 32-bit system?
Option A:	int
Option B:	long
Option C:	signed short
Option D:	unsigned short
7.	What is value of a in following expression? int a = 10 + 4.867;
Option A:	10

Option B:	14
Option C:	14.867
Option D:	14867
8.	<p>What will be the out put of following Program when user hits 1 as input</p> <pre>#include <stdio.h> void main() { int ch; printf("enter a value between 1 to 2:"); scanf("%d", &ch); switch (ch) { case 1: printf("1\n"); printf("hi"); break; printf("hi"); default: printf("2\n"); } }</pre>
Option A:	hi
Option B:	1 hi
Option C:	2
Option D:	hi 1
9.	A Pointer is
Option A:	A Keyword Used to create Variables
Option B:	A variable that store address of an Instruction
Option C:	A variable that stores address of other Variable
Option D:	Imaginary Value
10.	<p>What will be the output of the following program?</p> <pre>int main() { int a,b,c,d,e,f,g,h,k; a=8, b=4, c=2, d=1, e=5, f=20; printf(“%d\n”,a+b-(c+d)*3%e+f/9); return 0; }</pre>
Option A:	10
Option B:	9
Option C:	8
Option D:	20

Q2	Solve any Two	(10 Marks each)
a)	Write an algorithm and a draw flowchart whether the entered number is an Armstrong or not.	
b)	Write a C-program to create array of structures in order to store details of almost 100 books. The book details are book name, book price, book page number and book author name.	

c)	Write a short Note with example on following (Any Two) 1. Primitive Data Types in C 2. Arithmetic and Logical Operator in C 3. Arrays in C 4. Pointers in C
----	---

Q3	Solve any Two (10 Marks each)
a)	Write a program to find largest and smallest elements of an array.
b)	What are strings and give any four string related functions with suitable example.
c)	Write a C program to display following pattern using nested loops. 1 2 1 3 2 1 4 3 2 1 5 4 3 2 1

Q4	Solve any Two (10 Marks each)
a)	What is recursion? Write a program using recursion to find the factorial value of given integer number.
b)	Explain call by value and call by reference with suitable example.
c)	Write an algorithm to find the average of 10 numbers, also draw a flowchart to find average of 10 numbers.

University of Mumbai
Curriculum Scheme: Rev2016
All Programs
Examination: FE Semester II
Course Name: Communication Skills
Paper / Subject Code: Communication Skills
Total Marks: 40
Duration: 1 hour 30 minutes

Q.1 Choose the correct option for following questions. All the questions are compulsory and carry 2 marks each. 10 Marks

Note: Correct option is given in BOLD letter.

- The origin of the word communication is _____
A. communicare
B. communicate
C. communication
D. communicative
- The first language which we learn or speak as a child _____
A. jargon
B. mother tongue
C. vernacular
D. dialect
- What is a sentence?
A) A group of ideas.
B) A group of words that communicate a complete thought.
C) A set of rules to write correctly.
D) A set of words that is grammatically correct
- Technical writing demands _____ use of language.
A) Figurative
B) poetic

C) factual

D) dramatic

5. Where are the details of the Enclosures mentioned?

A. At the beginning

B. Below the signature columns

C. Right hand side of the letter

D. In the main body of the letter

Q.2 Attempt any 2.

10 Marks

A. Write short note on

1. Seven Cs in business letter

Example should be given with the principle (Any 5 principles should be explained correctly) each principle carries 1 mark.

2. Types of barriers in communication

At least 5 types of the barriers with examples should be explained correctly. (3 marks)

How to overcome the barrier should be explained (2 marks)

B. For the following communication situations identify the sender, receiver, message, medium, channel and feedback.

1. A Project Report Presentation

Sender: Student/presenter (1 mark)

Receiver: Teacher/expert/audience (1 mark)

Message: Information/data in the report to be presented (1 mark)

Medium/channel: Mike, face to face oral communication (1 mark)

Feedback: Questions/doubts of the audience and/or appreciation (1 mark)

2. The Section Head calls the meeting of subordinates to discuss the reasons in the fall in the production.

Sender: Section Head (1 mark)

Receiver: Subordinates/audience (1 mark)

Message: the reasons in the fall in the production (1 mark)

Medium/channel: Mike, face to face oral communication (1 mark)

Feedback: Questions/doubts of the audience and/or appreciation (1 mark)

C. Write short note on

1. SQ3R technique in reading

Survey, Question, Reading, Recite and Review (Correct explanation will get 2.5 marks)

2. Proteomics and its impact on communication at workplace

Proximity: definition, meaning and four zones (correct info will get 1.5 marks)

Impact of Proximity at workplace: 1 mark

Q.3 Attempt any 2.

10 Marks

A. Choose the useful app for an android mobile and give instructions to download and operate the same.

Any 6 correct instructions should be given 5 marks.

B. You are the Branch Manager of “Star Group of Companies Pvt Ltd.” Pune. You want to set up a new branch office in Kolkata. Place an order for office furniture to “Wooden Rock Planet Pvt Ltd”, Mumbai.

Correct Format/layout should get 2 marks

Correct write up should be given 2 marks

Neatness and professional look of the letter should get 1 mark

C. Write short Notes on

1. Complete Block Format with Layout

Correct format/ layout should be given 3 marks

Explanation of the elements should be given 2 marks

2. The importance of grammar and vocabulary in the language skills

Suitable explanation should get 3 marks

Grammatical accuracy should get 2 marks

Q.4 Attempt any 2.

Marks 10

A. One word substitution

1. One who loves mankind: **Philanthropist**
2. One who looks positive side of every problem: **Optimist**
3. One who eats human flesh: **Cannibal**
4. One who speaks more languages: **Multilingual, Polyglot**
5. One who supervise in the examination: **Supervisor, Invigilator**

Correct answer should get 1 mark each.

B. Write a detailed note on the Communication Process with diagrammatic representation. Mention the details of the elements in communication process with a suitable example.

Communication definition and example: 1 mark

Process/Cycle (diagram): 1 mark

Elements with correct explanation: 2 marks

Suitable example: 1 mark

C. Superstar Cosmetics, Mumbai have complained that they receive a consignment of 100 ng of body sprays in damaged condition and have asked for adjustment, they have attributed the damage to defective packaging. On behalf of Sam Perfumes and Cosmetics, Mumbai write a suitable reply.

Correct Format/layout should get 2 marks

Correct write up should be given 2 marks

Neatness and professional look of the letter should get 1 mark